

AMC Quality System
QMI is Accredited by:



ISO 9001 Certified
Certificate #006697



Dutch Council
for Accreditation



more capacity • residential/commercial service

25 PSI MAOP and 425 cfh at 1/2-inch w.c. differential

AL-425

AL-425

- One-piece, die-cast aluminum case
- Oil impregnated, self-lubricating bearings
- Convulated duramic diaphragms
- Rigid, reinforced flag rods
- Graphite-filled, phenolic valves
- Long-life grommet seals
- Automatic meter reader compatibility
- Temperature compensation available from -30°F to 140°F
- 10 or 25 PSI MAOP
- 20 LT, 30 LT, 45 LT and #3-4 Sprague connection sizes
- Full warranty
- Pointer or odometer index

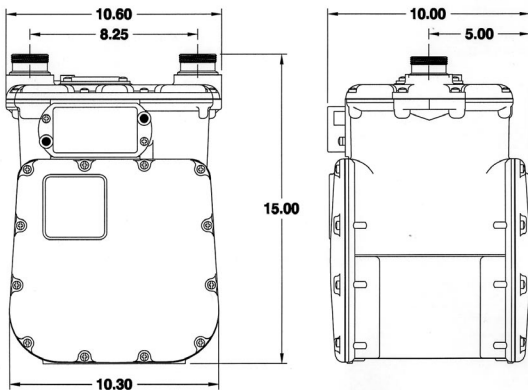

WEIGHT = 21 lbs.

Reference Materials

Installation Instructions AIM-3715
 Operation/Maintenance
 Manual & Video 52722P002
 Repair Parts List RPL-3806

APPLICATIONS —

This meter is ideally suited for larger residential or small commercial/industrial installations. Its 25 PSIG MAOP case-rating affords the opportunity to utilize pressure factor measurement. Pressure equivalent indexes are available.

Rated Gas Capacity For 0.60 S.G. Gas

Inlet Pressure PSIG	Inches W.C. Differential	Capacity SCFH
.25	1/2"	425 ^{1,2}
.25	2"	898
1	2"	920
2	2"	955
5	2"	1038
10	2"	1154
15	2"	1269
20	2"	1367
25	2"	1462

1 - Propane - 268 cfh
 2 - Butane - 234 cfh

AL-425 CAPACITY CURVE @ .25 PSIG inlet

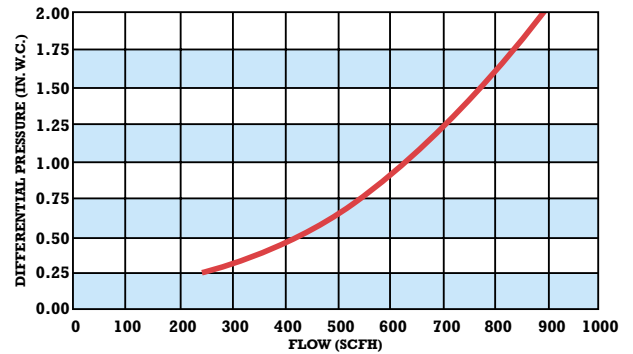

AL-425 PROOF CURVE

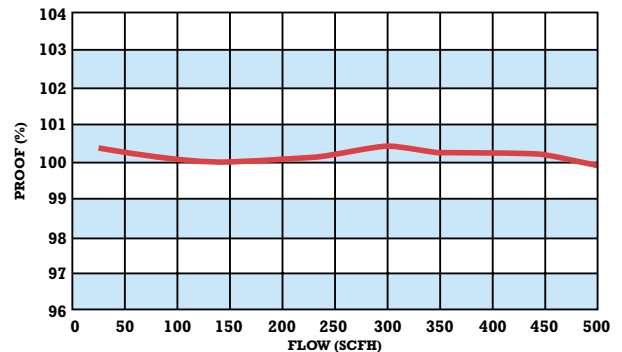

Order Information:

Model No.: _____
 Regular or Temperature Compensated: _____
 U.S. or Metric: _____
 Size of Connection: _____
 Type of Index: _____
 Proof Preference: 100 +/- 1% _____
 Standard Color – ASA #49 Grey: _____
 Contact American Meter with any questions or orders at the address and phone number below.



American Meter
 300 Welsh Road, Building One • Horsham, PA 19044-2234 • USA
 Tel: (215) 830-1800 • Fax: (215) 830-1890



Canadian Meter
 3037 Derry Road, West • Milton, Ontario L9T 2X6 • Canada
 Tel: (905) 878-2361 • Fax: (905) 878-5758