

1800CPB2 Pilot-Loaded Service Regulators

Technical Bulletin

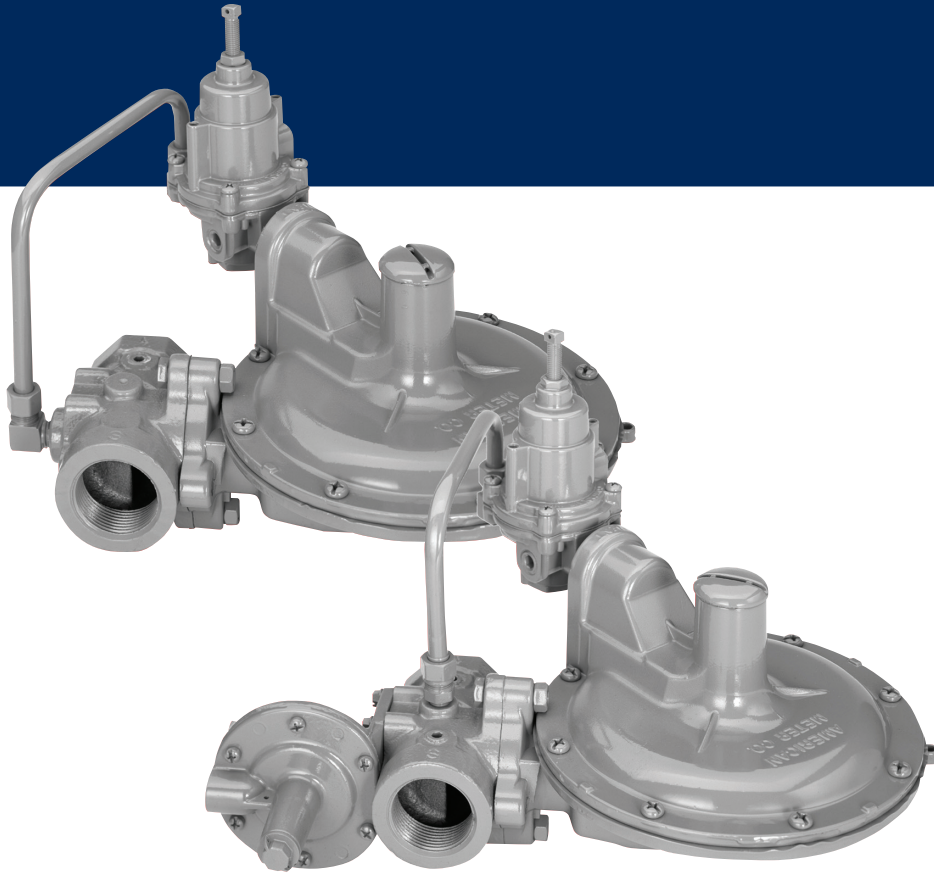

Table of Contents

1800CPB2 Regulator Information	2-3
1800CPB2 Capacity Performance	4-6
<i>1-1/4" Models, 1" Models, 3/4" Models</i>	
Typical Performance Data	7
Overpressure Shut-Off (OPSO) Regulators	7
1800CPB2 Service Regulators	7
<i>Full-Open Regulator Relief Capacity</i>	
Regulator Assembly Positions	8
<i>1800CPB2-90°</i>	
<i>1883CPB2</i>	
<i>1800CPB2-180°</i>	
<i>Regulator Descriptions, Orifice Sizes,</i>	
<i>Maximum Recommended Inlet Pressure</i>	
1800CPB2 Service Regulators	9
<i>Construction, Ordering Information,</i>	
<i>Shipping Weight, Pressure Rating</i>	

1800CPB2 Regulator Information

General Information

The American Meter Series 1800CPB2 pressure regulator is designed for natural gas applications and features a compact, lightweight design for fast, easy installation.

The 1800CPB2 regulator consists of a main regulator and a pilot regulator. It is a downstream bleed, pressure loaded regulator, designed to provide stability of operation for precise and constant outlet metering pressure control. The regulator is capable of handling varying inlet pressures up to 125 PSIG while controlling a set constant outlet pressure (1 to 30 PSIG) within $\pm 1\%$ of the absolute set pressure over a wide range of flow rates.

The main regulator is normally closed, furnished with one spring (for all outlet pressures) to close the regulator if loading pressure fails. The pilot regulator outlet line mounts to the main regulator vent and connection tubing brings the main regulator inlet pressure to the pilot regulator inlet.

The pilot regulator (one spring controls all outlet pressures from 1 PSIG to 30 PSIG) is used to load pressure on the diaphragm of the main regulator. Adjustment of the pilot regulator depends upon the inlet pressure and outlet pressure range desired. The pilot regulator using upstream pressure as its supply, reduces this pressure to a pre-determined value and then loads the main regulator diaphragm. The loading pressure overcomes the force of the main regulator spring causing the main regulator to open.

Exclusive Seven-Step Corrosion Protection

The protective finish on the Series 1800CPB2 regulators resists corrosive effects of weather and harsh environments better than any other in the industry. Each precision die-cast aluminum regulator is treated inside and out with a special conversion coating that's part of an exclusive, seven-step finishing process. This coating greatly inhibits oxidation of the metal's surface that can eventually compromise the integrity of the metal. It also prevents finish paint from cracking and blistering. A single-coat polyester primer and the high solid polyurethane top coat provide a long-lasting protection to all exterior regulator surfaces. The American Meter conversion coating process meets all environmental protection regulations.

High Tensile Strength Valve Bodies

Each Series of 1800CPB2 regulators is equipped with a high tensile strength cast-iron valve body and features extra heavy wall thickness. This provides maximum strength to withstand installation stresses without damage and prevents thread galling experienced with aluminum.

Series 1800CPB2 regulator valve bodies are treated with a five-step metal finishing process. The treated metal is primer painted with a single-coat polyester paint.

Available 180° valve body sizes are:
3/4" x 3/4", 3/4" x 1", 1" x 1", 1" x 1-1/4" and
1-1/4" x 1-1/4" NPT or BSP-TR.

Available 90° valve body sizes (1800CPB2 only) are:
3/4" x 3/4", 3/4" x 1", 1" x 1" NPT.

Application

The 1800CPB2 regulator is designed for pressure reducing service requiring stability and metering accuracy. They are used on gas distribution systems as intermediate or low-pressure regulators. They are also effective for large farm and commercial operations with widely varying inlet pressures up to 125 PSIG with accurate control of outlet pressures between 1 PSIG and 30 PSIG. 1800CPB2 regulators are excellent for use with American Meter large capacity meters as well as with American Meter domestic meters. Model 1883CPB2 is equipped with overpressure shut-off (OPSO) that provides protection against downstream overpressure (see page 7).

The 1800CPB2 regulator will accurately control the metering pressure to a constant value, thus the pressure correction factor becomes a constant factor for a given metering pressure. The pressure-corrected volume equals meter volume multiplied by the pressure factor constant.

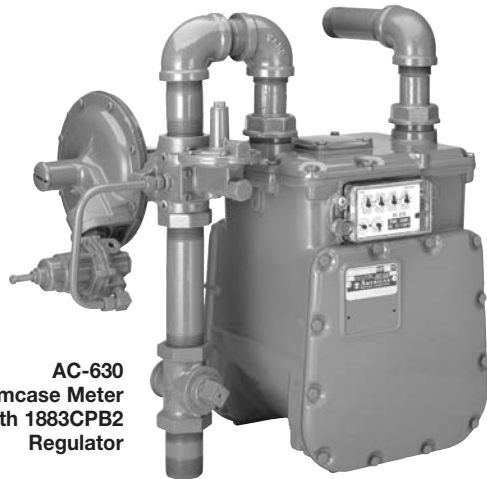

AC-630
Aluminumcase Meter
with 1883CPB2
Regulator

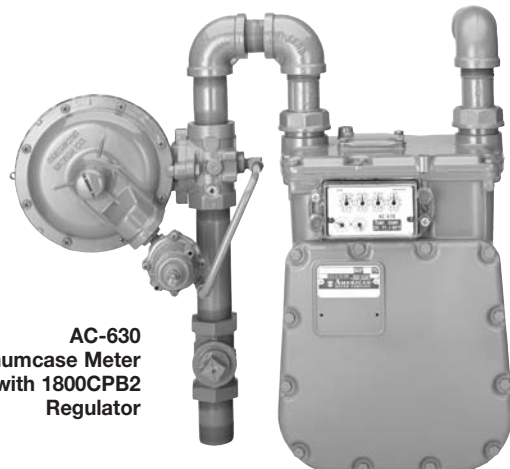

AC-630
Aluminumcase Meter
with 1800CPB2
Regulator

1800CPB2 Service Regulators

Fixed Factor Measurement

Fixed factor measurement is the measurement of gas at a controlled, elevated pressure without the use of an automatic correcting device to correct the volume for variations from base or contract pressure. The 1800CPB2 regulator provides accurately controlled, constant metering pressure for this application.

Volume of gas being metered at other than base pressure must be corrected to base or contract conditions. The American Gas Association specifies that a cubic foot of gas at base conditions be defined as the quantity which occupies a volume of one cubic foot at a pressure of 14.73 PSIA and at a temperature of 60°F.

Therefore, to determine the volume of gas at medium or high pressure, the volume must be corrected to base or contract pressure.

The correction factor to correct volume for pressure is determined from Boyle's Law:

$$\text{Volume Corrected} = \text{Volume Metered} \times \frac{\text{Metering Pressure} + \text{Atmospheric Pressure}}{\text{Base Pressure}}$$

Where temperature varies, American Meter recommends the 1800CPB2 regulator be used with a pressure compensating index for the desired metering pressure and with an American Meter temperature compensated meter to provide accurate flow measurement without subsequent calculations.

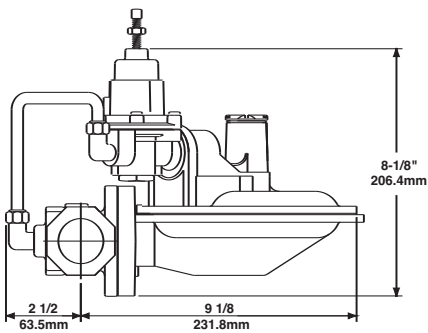
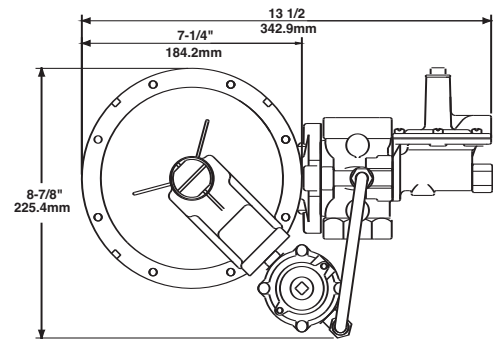
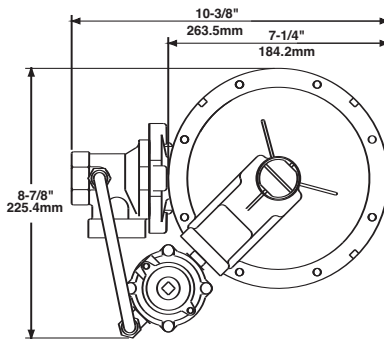
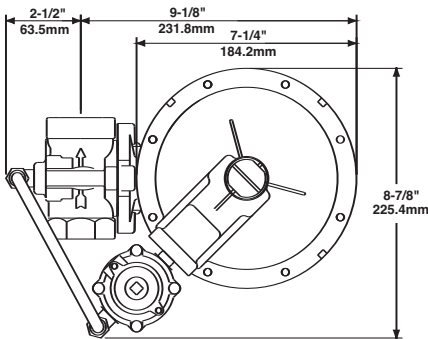

1800CPB2 - 180°

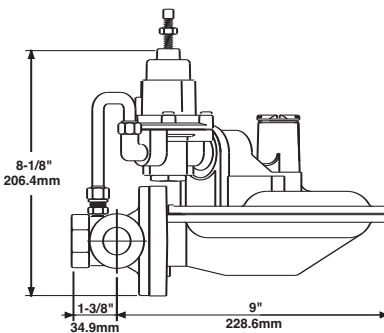

1800CPB2 - 90°

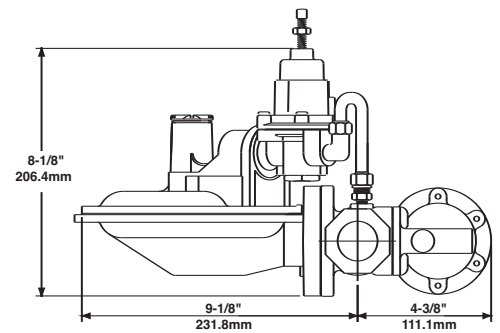

1883CPB2

1800CPB2 Regulator Capacity Performance

Capacity 1-1/4" Model 1800CPB2 Regulator

1/8" x 3/16" Orifice

1800B2 Capacity SCFH (m ³ /h)								
Outlet Pressure PSIG (bar)	Inlet Pressure PSIG (bar)							
	10 (0.69)	15 (1.03)	25 (1.72)	35 (2.41)	50 (3.45)	80** (5.52)	100 (6.89)	125 (8.62)
1 (0.07)	350 (9.9)	450 (12.7)	600 (17.0)	750 (21.2)	1000 (28.3)	1450 (41.1)	1800 (51.0)	1900 (53.8)
2 (0.14)	350 (9.9)	450 (12.7)	600 (17.0)	750 (21.2)	1000 (28.3)	1450 (41.1)	1800 (51.0)	1900 (53.8)
5 (0.34)	300 (8.5)	400 (11.3)	600 (17.0)	750 (21.2)	1000 (28.3)	1450 (41.1)	1750 (49.5)	1900 (53.8)
10 (0.69)	—	350 (9.9)	600 (17.0)	750 (21.2)	1000 (28.3)	1450 (41.1)	1750 (49.5)	1900 (53.8)
20 (1.38)	—	—	450 (12.7)	700 (19.8)	1000 (28.3)	1400 (39.6)	1750 (49.5)	1900 (53.8)
30 (2.07)	—	—	—	550 (15.6)	950 (26.9)	1400 (39.6)	1750 (49.5)	1900 (53.8)

5/16" Orifice

1800B2 Capacity SCFH (m ³ /h)								
Outlet Pressure PSIG (bar)	Inlet Pressure PSIG (bar)							
	10 (0.69)	15 (1.03)	25 (1.72)	35 (2.41)	50 (3.45)	80** (5.52)	100 (6.89)	125 (8.62)
1 (0.07)	2000 (56.6)	2600 (73.6)	3900 (110.4)	4900 (138.7)	6400 (181.1)	—	—	—
2 (0.14)	1900 (53.8)	2600 (73.6)	3800 (107.5)	4900 (138.7)	6300 (178.3)	—	—	—
5 (0.34)	1500 (42.5)	2300 (65.1)	3400 (96.2)	4600 (130.2)	6100 (172.6)	8500 (240.6)	—	—
10 (0.69)	—	1700 (48.1)	3200 (90.6)	4500 (127.4)	6000 (169.8)	8500 (240.6)	10200 (288.7)	—
20 (1.38)	—	—	2000 (56.6)	3800 (107.5)	5600 (158.5)	8500 (240.6)	10200 (288.7)	—
30 (2.07)	—	—	—	2400 (67.9)	4800 (135.8)	8000 (226.4)	10200 (288.7)	—

3/16" Orifice

1800B2 Capacity SCFH (m ³ /h)								
Outlet Pressure PSIG (bar)	Inlet Pressure PSIG (bar)							
	10 (0.69)	15 (1.03)	25 (1.72)	35 (2.41)	50 (3.45)	80** (5.52)	100 (6.89)	125 (8.62)
1 (0.07)	800 (22.7)	1050 (29.7)	1400 (39.6)	1750 (49.5)	2300 (65.1)	3400 (96.2)	4100 (116.0)	4200 (118.9)
2 (0.14)	800 (22.7)	1000 (28.3)	1400 (39.6)	1750 (49.5)	2300 (65.1)	3350 (94.8)	4100 (116.0)	4200 (118.9)
5 (0.34)	700 (19.8)	950 (26.9)	1350 (38.2)	1750 (49.5)	2250 (63.7)	3300 (93.4)	4000 (113.2)	4200 (118.9)
10 (0.69)	—	700 (19.8)	1350 (38.2)	1750 (49.5)	2250 (63.7)	3300 (93.4)	4000 (113.2)	4200 (118.9)
20 (1.38)	—	—	1000 (28.3)	1600 (45.3)	2250 (63.7)	3200 (90.6)	4000 (113.2)	4200 (118.9)
30 (2.07)	—	—	—	1000 (28.3)	2150 (60.8)	3200 (90.6)	3900 (110.4)	4200 (118.9)

3/8" Orifice

1800B2 Capacity SCFH (m ³ /h)								
Outlet Pressure PSIG (bar)	Inlet Pressure PSIG (bar)							
	10 (0.69)	15 (1.03)	25 (1.72)	35 (2.41)	50 (3.45)	80** (5.52)	100 (6.89)	125 (8.62)
1 (0.07)	2300 (65.1)	3100 (87.7)	4400 (124.5)	5300 (150.0)	7150 (202.3)	—	—	—
2 (0.14)	2200 (62.3)	3000 (84.9)	4400 (124.5)	5300 (150.0)	7200 (203.8)	—	—	—
5 (0.34)	1700 (48.1)	2600 (73.6)	4050 (114.6)	5300 (150.0)	7150 (202.3)	—	—	—
10 (0.69)	—	2000 (56.6)	3600 (101.9)	5050 (142.9)	7050 (199.5)	—	—	—
20 (1.38)	—	—	2300 (65.1)	4200 (118.9)	6600 (186.8)	—	—	—
30 (2.07)	—	—	—	2800 (79.2)	6000 (169.8)	—	—	—

1/4" Orifice

1800B2 Capacity SCFH (m ³ /h)								
Outlet Pressure PSIG (bar)	Inlet Pressure PSIG (bar)							
	10 (0.69)	15 (1.03)	25 (1.72)	35 (2.41)	50 (3.45)	80** (5.52)	100 (6.89)	125 (8.62)
1 (0.07)	1300 (36.8)	1700 (48.1)	2500 (70.8)	3150 (89.1)	4100 (116.0)	6100 (172.6)	6700 (189.6)	—
2 (0.14)	1300 (36.8)	1700 (48.1)	2500 (70.8)	3150 (89.1)	4100 (116.0)	6100 (172.6)	7200 (203.8)	—
5 (0.34)	1000 (28.3)	1500 (42.5)	2400 (68.0)	3100 (87.7)	4000 (113.2)	5850 (165.6)	7100 (200.9)	—
10 (0.69)	—	1200 (34.0)	2200 (62.3)	3050 (86.3)	3900 (110.4)	5850 (165.6)	7100 (200.9)	—
20 (1.38)	—	—	1400 (39.6)	2600 (73.6)	3900 (110.4)	5850 (165.6)	7100 (200.9)	—
30 (2.07)	—	—	—	1600 (45.3)	3400 (96.2)	5800 (164.1)	7100 (200.9)	—

1/2" Orifice

1800B2 Capacity SCFH (m ³ /h)								
Outlet Pressure PSIG (bar)	Inlet Pressure PSIG (bar)							
	10 (0.69)	15 (1.03)	25 (1.72)	35 (2.41)	50 (3.45)	80** (5.52)	100 (6.89)	125 (8.62)
1 (0.07)	3200 (90.6)	4500 (127.4)	6350 (179.7)	7500 (212.3)	—	—	—	—
2 (0.14)	3200 (90.6)	4400 (124.5)	6300 (178.3)	7800 (220.7)	—	—	—	—
5 (0.34)	2600 (73.6)	4000 (113.2)	6100 (172.6)	7900 (223.6)	—	—	—	—
10 (0.69)	—	—	5500 (155.7)	7700 (217.9)	—	—	—	—
20 (1.38)	—	—	3600 (101.9)	6400 (181.1)	—	—	—	—
30 (2.07)	—	—	—	4150 (117.4)	—	—	—	—

Note: Capacity figures shown represent the capability of the regulator when installed with **adequately sized downstream piping**.

The following table may be used as a guide in sizing downstream piping:

Pipe Size	Maximum Flow – SCFH
3/4"	2,000
1"	3,000
1-1/4"	6,000
1-1/2"	9,000

** Set Inlet Pressure for all outlet pressures
Set Flow 200 SCFH of 0.60 Specific Gravity

At given outlet pressure setting, the outlet pressure is controlled to ±1% absolute outlet pressure over full range of inlet pressure shown.

1800CPB2 Regulator Capacity Performance

Capacity 1" Model 1800CPB2 Regulator

1/8" x 3/16" Orifice

Outlet Pressure PSIG (bar)	1800B2 Capacity SCFH (m ³ /h)							
	Inlet Pressure PSIG (bar)							
	10 (0.69)	15 (1.03)	25 (1.72)	35 (2.41)	50 (3.45)	80** (5.52)	100 (6.89)	125 (8.62)
1 (0.07)	400 (11.3)	450 (12.7)	600 (17.0)	800 (22.7)	1000 (28.3)	1500 (42.5)	1800 (51.0)	1900 (53.8)
2 (0.14)	350 (9.9)	450 (12.7)	600 (17.0)	800 (22.7)	1000 (28.3)	1500 (42.5)	1800 (51.0)	1900 (53.8)
5 (0.34)	300 (8.5)	450 (12.7)	600 (17.0)	800 (22.7)	1000 (28.3)	1500 (42.5)	1800 (51.0)	1900 (53.8)
10 (0.69)	—	375 (10.6)	600 (17.0)	800 (22.7)	1000 (28.3)	1500 (42.5)	1800 (51.0)	1900 (53.8)
20 (1.38)	—	—	450 (12.7)	750 (21.2)	1000 (28.3)	1500 (42.5)	1800 (51.0)	1900 (53.8)
30 (2.07)	—	—	—	500 (14.2)	950 (26.9)	1500 (42.5)	1800 (51.0)	1900 (53.8)

5/16" Orifice

Outlet Pressure PSIG (bar)	1800B2 Capacity SCFH (m ³ /h)							
	Inlet Pressure PSIG (bar)							
	10 (0.69)	15 (1.03)	25 (1.72)	35 (2.41)	50 (3.45)	80** (5.52)	100 (6.89)	125 (8.62)
1 (0.07)	1850 (52.4)	2500 (70.8)	3500 (99.1)	4000 (113.2)	4200 (118.9)	4500 (127.4)	—	—
2 (0.14)	1750 (49.5)	2400 (68.0)	3500 (99.1)	4300 (121.7)	5000 (141.5)	5500 (155.7)	—	—
5 (0.34)	1400 (39.6)	1950 (55.2)	3250 (92.0)	4200 (118.9)	5500 (155.7)	6600 (186.8)	7200 (203.8)	—
10 (0.69)	—	1500 (42.5)	2900 (82.1)	4000 (113.2)	5500 (155.7)	7000 (198.1)	7600 (215.1)	—
20 (1.38)	—	—	1800 (51.0)	3200 (90.6)	4900 (138.7)	7500 (212.3)	9000 (254.7)	—
30 (2.07)	—	—	—	1950 (55.2)	4300 (121.7)	7300 (206.6)	9000 (254.7)	—

3/16" Orifice

Outlet Pressure PSIG (bar)	1800B2 Capacity SCFH (m ³ /h)							
	Inlet Pressure PSIG (bar)							
	10 (0.69)	15 (1.03)	25 (1.72)	35 (2.41)	50 (3.45)	80** (5.52)	100 (6.89)	125 (8.62)
1 (0.07)	800 (22.7)	1000 (28.3)	1250 (35.4)	1650 (46.7)	2200 (62.3)	3200 (90.6)	3800 (107.5)	—
2 (0.14)	800 (22.7)	1000 (28.3)	1350 (38.2)	1700 (48.1)	2200 (62.3)	3200 (90.6)	3800 (107.5)	—
5 (0.34)	700 (19.8)	950 (26.9)	1350 (38.2)	1700 (48.1)	2200 (62.3)	3200 (90.6)	3800 (107.5)	—
10 (0.69)	—	800 (22.7)	1300 (36.8)	1700 (48.1)	2200 (62.3)	3200 (90.6)	3800 (107.5)	4000 (113.2)
20 (1.38)	—	—	1000 (28.3)	1600 (45.3)	2200 (62.3)	3200 (90.6)	3800 (107.5)	4000 (113.2)
30 (2.07)	—	—	—	1100 (31.2)	2050 (58.0)	3200 (90.6)	3800 (107.5)	4000 (113.2)

3/8" Orifice

Outlet Pressure PSIG (bar)	1800B2 Capacity SCFH (m ³ /h)							
	Inlet Pressure PSIG (bar)							
	10 (0.69)	15 (1.03)	25 (1.72)	35 (2.41)	50 (3.45)	80** (5.52)	100 (6.89)	125 (8.62)
1 (0.07)	2100 (59.4)	2800 (79.2)	3700 (104.7)	4000 (113.2)	4450 (125.9)	4900 (138.7)	—	—
2 (0.14)	2200 (62.3)	2600 (73.6)	3400 (96.2)	4200 (118.9)	4700 (133.0)	5350 (151.4)	—	—
5 (0.34)	1750 (49.5)	2500 (70.8)	3600 (101.9)	4600 (130.2)	5000 (141.5)	7300 (206.6)	—	—
10 (0.69)	—	1500 (42.5)	3400 (96.2)	4900 (138.7)	6100 (172.6)	7800 (220.7)	—	—
20 (1.38)	—	—	2200 (62.3)	4100 (116.0)	6000 (169.8)	8800 (249.0)	—	—
30 (2.07)	—	—	—	2650 (75.0)	5400 (152.8)	7300 (206.6)	—	—

1/4" Orifice

Outlet Pressure PSIG (bar)	1800B2 Capacity SCFH (m ³ /h)							
	Inlet Pressure PSIG (bar)							
	10 (0.69)	15 (1.03)	25 (1.72)	35 (2.41)	50 (3.45)	80** (5.52)	100 (6.89)	125 (8.62)
1 (0.07)	1350 (38.2)	1750 (49.5)	2400 (68.0)	3000 (84.9)	3900 (110.4)	4500 (127.4)	4800 (135.8)	—
2 (0.14)	1300 (36.8)	1700 (48.1)	2400 (68.0)	3000 (84.9)	3900 (110.4)	5300 (150.0)	5500 (155.7)	—
5 (0.34)	1000 (28.3)	1450 (41.0)	2300 (65.1)	2950 (83.5)	3900 (110.4)	5600 (158.5)	6000 (169.8)	—
10 (0.69)	—	1100 (31.2)	2100 (59.5)	2900 (82.1)	3800 (107.5)	5600 (158.5)	6700 (189.6)	—
20 (1.38)	—	—	1300 (36.8)	2400 (68.0)	3600 (101.9)	5600 (158.5)	6700 (189.6)	—
30 (2.07)	—	—	—	1550 (43.9)	3150 (89.1)	5600 (158.5)	6700 (189.6)	—

1/2" Orifice

Outlet Pressure PSIG (bar)	1800B2 Capacity SCFH (m ³ /h)							
	Inlet Pressure PSIG (bar)							
	10 (0.69)	15 (1.03)	25 (1.72)	35 (2.41)	50 (3.45)	80** (5.52)	100 (6.89)	125 (8.62)
1 (0.07)	2900 (82.1)	3350 (94.8)	4200 (118.9)	4200 (118.9)	—	—	—	—
2 (0.14)	3000 (84.9)	3400 (96.2)	4400 (124.5)	4900 (138.7)	—	—	—	—
5 (0.34)	2400 (67.9)	3000 (84.9)	4200 (118.9)	4950 (140.1)	—	—	—	—
10 (0.69)	—	2400 (68.0)	4300 (121.7)	5350 (151.4)	—	—	—	—
20 (1.38)	—	—	3000 (84.9)	5400 (152.8)	—	—	—	—
30 (2.07)	—	—	—	3600 (101.9)	—	—	—	—

Note: Capacity figures shown represent the capability of the regulator when installed with **adequately sized downstream piping**.

The following table may be used as a guide in sizing downstream piping:

Pipe Size	Maximum Flow – SCFH
3/4"	2,000
1"	3,000
1-1/4"	6,000
1-1/2"	9,000

** Set Inlet Pressure for all outlet pressures
Set Flow 200 SCFH of 0.60 Specific Gravity

At given outlet pressure setting, the outlet pressure is controlled to ±1% absolute outlet pressure over full range of inlet pressure shown.

1800CPB2 Regulator Capacity Performance

Capacity – 3/4" Model 1800CPB2 Regulator

1/8" x 3/16" Orifice

1800B2 Capacity SCFH (m ³ /h)								
Outlet Pressure PSIG (bar)	Inlet Pressure PSIG (bar)							
	10 (0.69)	15 (1.03)	25 (1.72)	35 (2.41)	50 (3.45)	80** (5.52)	100 (6.89)	125 (8.62)
1 (0.07)	375 (10.6)	450 (12.7)	600 (17.0)	775 (21.9)	1000 (28.3)	1450 (41.0)	1800 (51.0)	1900 (53.8)
2 (0.14)	375 (10.6)	450 (12.7)	600 (17.0)	775 (21.9)	1000 (28.3)	1500 (42.5)	1800 (51.0)	1900 (53.8)
5 (0.34)	350 (9.9)	450 (12.7)	600 (17.0)	800 (22.7)	1000 (28.3)	1500 (42.5)	1800 (51.0)	1900 (53.8)
10 (0.69)	—	400 (11.3)	600 (17.0)	800 (22.7)	1000 (28.3)	1500 (42.5)	1800 (51.0)	1900 (53.8)
20 (1.38)	—	—	500 (14.2)	750 (21.2)	1000 (28.3)	1500 (42.5)	1800 (51.0)	1900 (53.8)
30 (2.07)	—	—	—	600 (17.0)	1000 (28.3)	1500 (42.5)	1800 (51.0)	1900 (53.8)

5/16" Orifice

1800B2 Capacity SCFH (m ³ /h)								
Outlet Pressure PSIG (bar)	Inlet Pressure PSIG (bar)							
	10 (0.69)	15 (1.03)	25 (1.72)	35 (2.41)	50 (3.45)	80** (5.52)	100 (6.89)	125 (8.62)
1 (0.07)	1500 (42.5)	2000 (56.6)	2200 (62.3)	2300 (65.1)	2350 (66.5)	—	—	—
2 (0.14)	1400 (39.6)	1900 (53.8)	2000 (56.6)	2400 (68.0)	2600 (73.6)	3100 (87.7)	3100 (87.7)	—
5 (0.34)	1400 (39.6)	2000 (56.6)	2500 (70.8)	2900 (82.1)	3150 (89.1)	3450 (97.6)	3600 (101.9)	—
10 (0.69)	—	1600 (45.3)	2700 (76.4)	3300 (93.4)	3700 (104.7)	4100 (116.0)	4200 (118.9)	—
20 (1.38)	—	—	1900 (53.8)	3300 (93.4)	4300 (121.7)	5300 (150.0)	5600 (158.5)	—
30 (2.07)	—	—	—	2300 (65.1)	4500 (127.4)	6100 (172.6)	6400 (181.1)	—

3/16" Orifice

1800B2 Capacity SCFH (m ³ /h)								
Outlet Pressure PSIG (bar)	Inlet Pressure PSIG (bar)							
	10 (0.69)	15 (1.03)	25 (1.72)	35 (2.41)	50 (3.45)	80** (5.52)	100 (6.89)	125 (8.62)
1 (0.07)	800 (22.7)	1000 (28.3)	1350 (38.2)	1700 (48.1)	2200 (62.3)	2500 (70.8)	2000 (56.6)	—
2 (0.14)	750 (21.2)	1000 (28.3)	1350 (38.2)	1700 (48.1)	2200 (62.3)	2650 (75.0)	2700 (76.4)	—
5 (0.34)	700 (19.8)	950 (26.9)	1300 (36.8)	1700 (48.1)	2200 (62.3)	3200 (90.6)	3100 (87.7)	—
10 (0.69)	—	800 (22.7)	1300 (36.8)	1700 (48.1)	2200 (62.3)	3200 (90.6)	3900 (110.4)	4000 (113.2)
20 (1.38)	—	—	1000 (28.3)	1550 (43.9)	2200 (62.3)	3200 (90.6)	3900 (110.4)	4000 (113.2)
30 (2.07)	—	—	—	1100 (31.2)	2100 (59.5)	3200 (90.6)	3850 (109.0)	4000 (113.2)

3/8" Orifice

1800B2 Capacity SCFH (m ³ /h)								
Outlet Pressure PSIG (bar)	Inlet Pressure PSIG (bar)							
	10 (0.69)	15 (1.03)	25 (1.72)	35 (2.41)	50 (3.45)	80** (5.52)	100 (6.89)	125 (8.62)
1 (0.07)	1600 (45.3)	1900 (53.8)	2000 (56.6)	2100 (59.5)	2300 (65.1)	—	—	—
2 (0.14)	1600 (45.3)	1900 (53.8)	2200 (62.3)	2500 (70.8)	2600 (73.6)	2900 (82.1)	—	—
5 (0.34)	1600 (45.3)	2100 (59.5)	2600 (73.6)	2800 (79.2)	3250 (92.0)	3450 (97.6)	—	—
10 (0.69)	—	1800 (51.0)	2800 (79.2)	3300 (93.4)	3600 (101.9)	4100 (116.0)	—	—
20 (1.38)	—	—	2250 (63.7)	3400 (96.2)	4500 (127.4)	5300 (150.0)	—	—
30 (2.07)	—	—	—	2600 (73.6)	4750 (134.4)	6500 (184.0)	—	—

1/4" Orifice

1800B2 Capacity SCFH (m ³ /h)								
Outlet Pressure PSIG (bar)	Inlet Pressure PSIG (bar)							
	10 (0.69)	15 (1.03)	25 (1.72)	35 (2.41)	50 (3.45)	80** (5.52)	100 (6.89)	125 (8.62)
1 (0.07)	1200 (34.0)	1600 (45.3)	2200 (62.3)	2800 (79.2)	2800 (79.2)	2500 (70.8)	2000 (56.6)	—
2 (0.14)	1200 (34.0)	1500 (42.5)	2200 (62.3)	2800 (79.2)	2800 (79.2)	2800 (79.2)	2500 (70.8)	—
5 (0.34)	1000 (28.3)	1400 (39.6)	2100 (59.5)	2600 (73.6)	2800 (79.2)	3300 (93.4)	3500 (99.1)	—
10 (0.69)	—	1100 (31.2)	2000 (56.6)	2600 (73.6)	3200 (90.6)	3800 (107.5)	4200 (118.9)	—
20 (1.38)	—	—	1300 (36.8)	2300 (65.1)	3500 (99.1)	4600 (130.2)	5100 (144.3)	—
30 (2.07)	—	—	—	1550 (43.9)	3000 (84.9)	5300 (150.0)	5900 (167.0)	—

1/2" Orifice

1800B2 Capacity SCFH (m ³ /h)								
Outlet Pressure PSIG (bar)	Inlet Pressure PSIG (bar)							
	10 (0.69)	15 (1.03)	25 (1.72)	35 (2.41)	50 (3.45)	80** (5.52)	100 (6.89)	125 (8.62)
1 (0.07)	1700 (48.1)	1900 (53.8)	2300 (65.1)	2400 (68.0)	—	—	—	—
2 (0.14)	1500 (42.5)	2150 (60.8)	2200 (62.3)	2300 (65.1)	—	—	—	—
5 (0.34)	2000 (56.6)	2400 (68.0)	2800 (79.2)	3100 (87.7)	3200 (90.6)	—	—	—
10 (0.69)	—	2400 (68.0)	3200 (90.6)	3500 (99.1)	3750 (106.1)	—	—	—
20 (1.38)	—	—	3000 (84.9)	4100 (116.0)	4600 (130.2)	—	—	—
30 (2.07)	—	—	—	3500 (99.1)	5300 (150.0)	—	—	—

Note: Capacity figures shown represent the capability of the regulator when installed with **adequately sized downstream piping**.

The following table may be used as a guide in sizing downstream piping:

Pipe Size	Maximum Flow – SCFH
3/4"	2,000
1"	3,000
1-1/4"	6,000
1-1/2"	9,000

** Set Inlet Pressure for all outlet pressures
Set Flow 200 SCFH of 0.60 Specific Gravity

At given outlet pressure setting, the outlet pressure is controlled to ±1% absolute outlet pressure over full range of inlet pressure shown.

Typical Performance Data

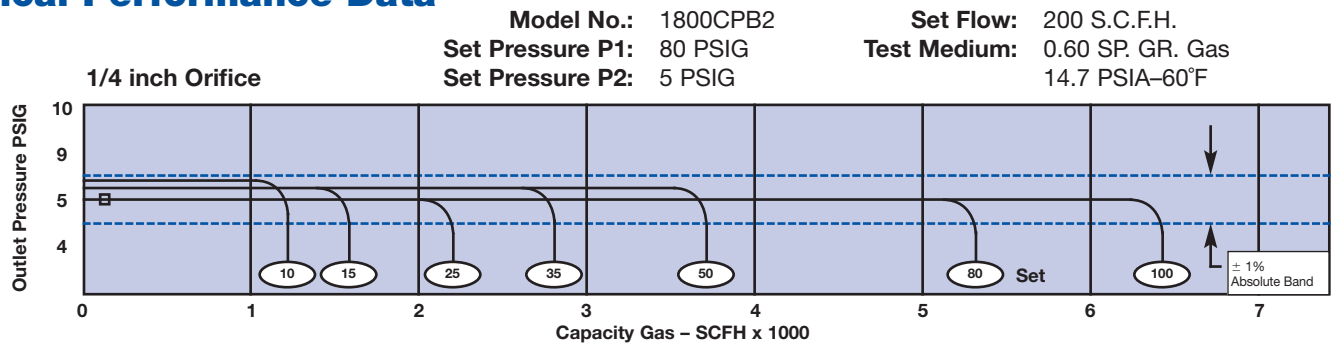

Overpressure Shut-off (OPSO) Regulators

General Information

Model 1883CPB2 regulators are compact units designed to regulate line pressure and to provide protection against any downstream overpressure.

Rugged, Compact OPSO Operates independently. The OPSO will shut off the gas supply in the event of a serious downstream pressure build-up.

Adjustable Overpressure Shut-Off Pressure is adjustable via the overpressure shut-off adjustment screw to settings from 5 to 15 PSIG and 15 to 40 PSIG depending on spring selected.

How the OPSO Operates

When the outlet pressure exceeds the OPSO set point, the pressure under the OPSO diaphragm (A) compresses the pressure spring (B) forcing the diaphragm stem (E) upwards and releasing plunger (D). This permits the shut-off spring (F) to force the shut-off disc (G) against the back side of the special double-ended orifice.

Shut-Off Assembly Range	Adjustable Trip Point Range
72978G096	5 to 15 PSIG
72978G097	15 to 40 PSIG

Note: The OPSO setting is preset at the factory to the desired trip point. To reset the OPSO, shut off gas supply and depressurize the regulator system, unscrew cap (C), pull back the plunger (D) until the diaphragm stem (E) repositions.

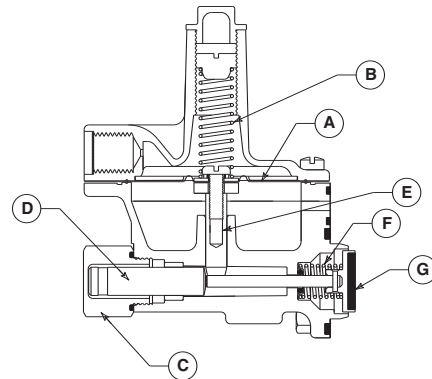
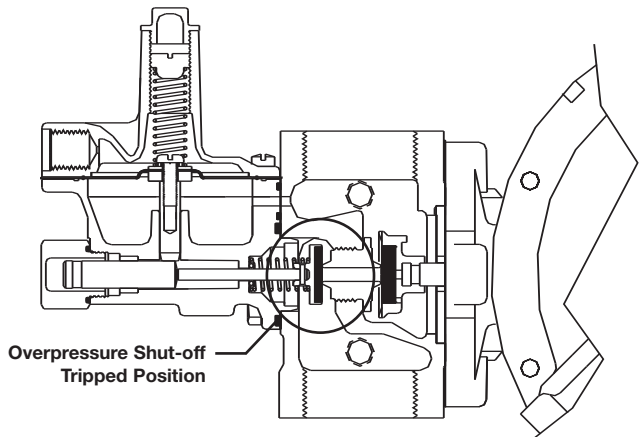

1800CPB2 Service Regulators

Full-Open Regulator Relief Capacity

For sizing downstream relief valves, use the following formulas to determine the regulator full-open capacity:

For critical flow rates

$$Q = 0.5 C \times \frac{P_1}{\sqrt{G}}$$

For sub-critical flows

$$Q = C \frac{\sqrt{P_2 h}}{\sqrt{G}}$$

Key

- Q = Maximum capacity of regulator
- C = Orifice constant (see table)
- P₁ = Inlet absolute pressure (PSIA)
- P₂ = Outlet absolute pressure (PSIA)
- h = Differential pressure (P₁-P₂)
- G = Specific gravity of gas

Orifice	C
1/8"	25
1/8" x 3/16"	25
3/16"	57
1/4"	98
5/16"	149
3/8"	208
1/2"	353
9/16"	421

Regulator Assembly Positions

For 1800CPB2-90° Models

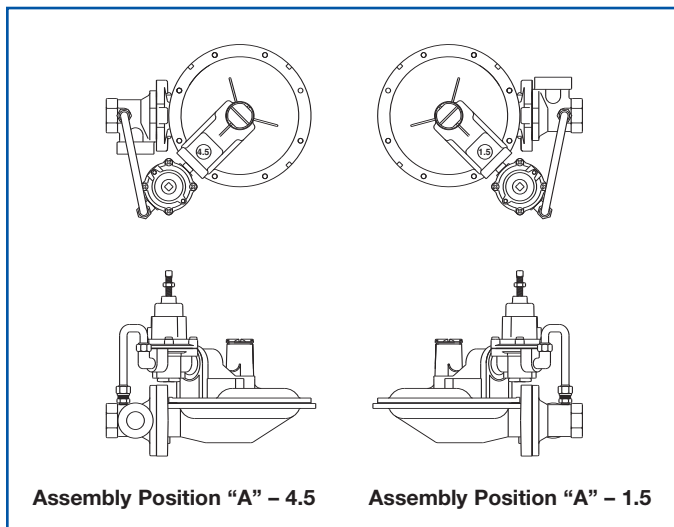

For 1800CPB2-180° Models

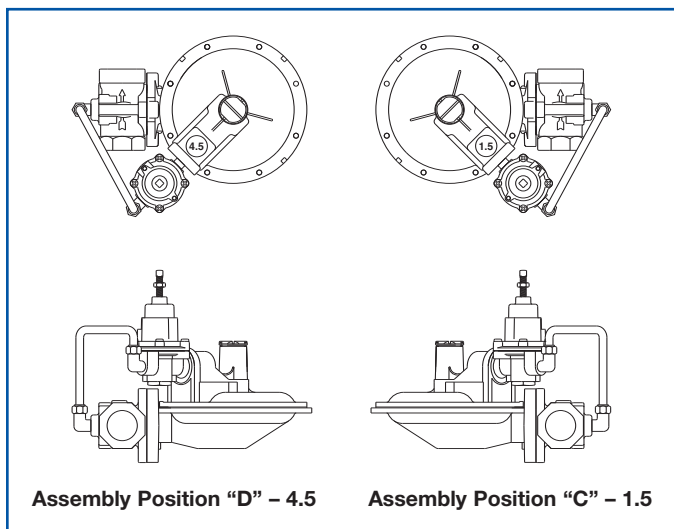

For 1883CPB2 Models

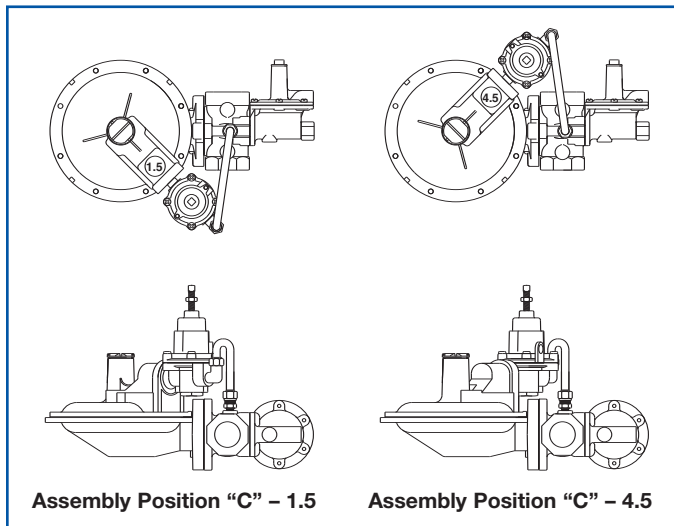

Regulator Descriptions

Model Number	Description
1800CPB2	Pilot loading regulator, non-relieving
1883CPB2	Pilot loading regulator, non-relieving with overpressure shutoff (OPSO)

Orifice Sizes

Orifice Size	Part Number	
	Standard	w/OPSO
1/8" x 3/16"	72494P030	72751P020
3/16"	72494P020	72751P011
1/4"	72494P021	72751P012
5/16"	72494P022	72751P013
3/8"	72494P023	72751P014
1/2"	72494P025	72751P016

Maximum Recommended Inlet Pressure

Orifice Size	Inlet Pressure PSIG (bar)
1/8" x 3/16"	125 (8.62)
3/16"	125 (8.62)
1/4"	100 (6.89)
5/16"	100 (6.89)
3/8"	80 (5.52)
1/2"	50 (3.45)

1800CPB2 Service Regulators

Construction

Lower Diaphragm Case – Precision die-cast aluminum with an exclusive seven-step advanced conversion coating, single-coat polyester primer and high solid polyurethane top coat.

Top Assembly – Precision die-cast aluminum with an exclusive seven-step advanced conversion coating, single-coat polyester primer and high solid polyurethane top coat.

Valve Body – Cast grey iron, undercoated, single-coat polyester primer and high solid polyurethane top coat.

Closing Spring – Steel, zinc plated and yellow chromate. Color coded for identification.

Diaphragm Plate – Steel, terne plated.

Seat Disc – Buna-N.

Orifice – Super high strength, corrosion-resistant, aluminum.

Lever – Steel, zinc plated and yellow chromate.

Vent Screen – Stainless steel.

Seal Plug – Precision, die-cast aluminum.

Corrosion Protection

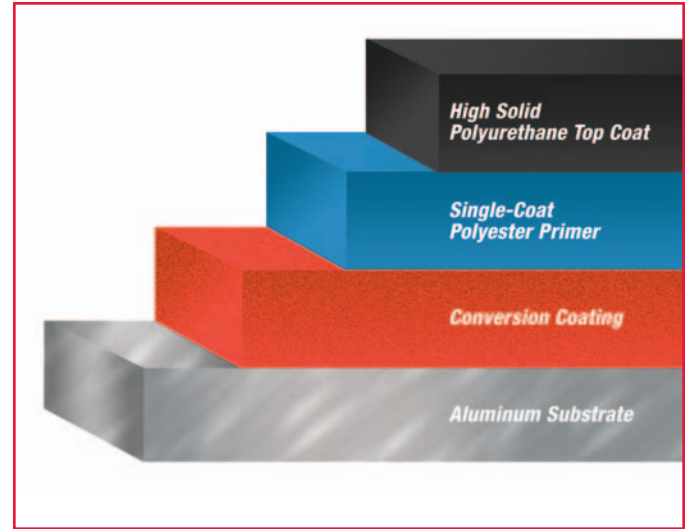

Ordering Information

- 1 Model number
- 2 Size of inlet and outlet connections
- 3 Inlet pressure, PSIG (*bar*)
- 4 Outlet pressure, PSIG (*bar*)
- 5 Flow, scfh (m³/h)
- 6 Kind and specific gravity of gas
- 7 Orifice size
- 8 Regulator assembly position
- 9 OPSO shut-off set point (1883CPB2 only)

Shipping Weight

8.4 lbs/carton of one regulator

Regulator Pressure Rating

125 PSIG (8.6 *bar*) = Maximum recommended inlet pressure for normal service. Maximum recommended pressure may vary with orifice size.

175 PSIG (12 *bar*) = Maximum inlet pressure for abnormal or emergency service, without causing damage to regulator case.

30 PSIG (2 *bar*) = Maximum outlet pressure for normal service.

45 PSIG (3.1 *bar*) = Maximum outlet pressure which can be contained by pressure carrying components (no flange leakage to atmosphere). ***If regulator is subjected to these conditions, it should be removed from service.***

50 PSIG (3.5 *bar*) = Maximum outlet pressure for abnormal service without damage to internal components. ***If regulator is subjected to these conditions, it should be removed from service.***

About Elster Group

Elster Group is the world's leading manufacturer and supplier of highly accurate, high quality, integrated metering and utilization solutions to the gas, electricity and water industries. In addition, through its subsidiary Ipsen International, it is the leading global manufacturer of high level thermo-chemical treatment equipment.

The group has over 8,500 staff, operations in 38 countries and serves over 115 markets around the world. Elster's high quality products and systems reflect the wealth of knowledge and experience gained from over 170 years of dedication to measuring precious resources and energy.

ISO 9001: 2000



Certificate No. 006697



Dutch Council
for Accreditation

Elster American Meter
2221 Industrial Road
Nebraska City, NE 68410
USA

T +1 402 873 8200
F +1 402 873 7616

www.elster-americanmeter.com

© 2008 Elster American Meter. All rights reserved

Information contained herein is subject to change without notice. Product specifications may change. Contact your Elster American Meter representative for the most current product information. Printed in the United States.

EAM-TB8520.6-EN-P - January 2008
Supersedes SB 8520.5