

SERIES WLD1800 & WLD1800R

GUIDED FLOAT TYPE DRAINER

INSTALLATION INSTRUCTIONS

INSTRUCTION PART NO. 2218700

REVISION 3

INSTALLATION

1. Before installing the drainer, blow out piping thoroughly to remove loose scale and dirt. Use pipe dope or teflon tape sparingly when attaching the drainer to the pipe. Observe the pressure limitation shown on the drainer label.
2. Install the drainer below the equipment being drained in a location easily accessible for maintenance and inspection. Be certain to install with flow in direction indicated in diagram.
3. Install a drip pocket to keep dirt away from the drainer.
4. Discharge piping should be amply sized to avoid excessive back pressures.
5. To provide for easy maintenance and service, install a block valve on each side of the drainer and install a strainer ahead of the inlet connection.
6. All valves should be full ported to achieve the rated capacity of the drainer.
7. If the discharge piping is to be elevated, be certain that the available differential pressure is adequate to permit proper drainage. Remember, two feet of lift equals approximately one psi.

ORDERING SPARE PARTS

Specify the description of the part. Indicate the Model Number, Size and Operating Pressure, which are shown on the name plate.

Typical Specification: Lever & Valve Assembly for WLD 1810R Liquid Drainer.

TROUBLESHOOTING

PROBLEM	CAUSE	ACTION
1) Drainer does not discharge.	a) Damaged float. b) Operating pressure too high.	a) Replace float. b) Install drainer suitable for operating pressure.
2) Drainer does not close.	a) Dirt lodged on seat. b) Worn out internals.	a) Clean drainer; install strainer. b) Replace internals; be certain to match the model no. and pressure.

Each Watson McDaniel Company Product is warranted against defects in material and workmanship for one year from date of shipment. This warranty extends to the first retail purchaser only. All defective material must be returned to the person from whom you purchased the Product, transportation prepaid, free of any liens or encumbrances, and if found to be defective will be repaired free of charge or replaced, at the warrantor's or seller's option. If the material is replaced, any replacement will be invoiced in the usual manner and after inspection of alleged defective material an adjustment will be made for depreciation caused by purchaser's use. In no event will Watson McDaniel Company be liable to do more than refund the original contract price. Incidental and consequential damages are excluded, whether under this warranty or otherwise. All implied warranties, including warranties of merchantability and fitness for a particular purpose, are disclaimed and excluded.

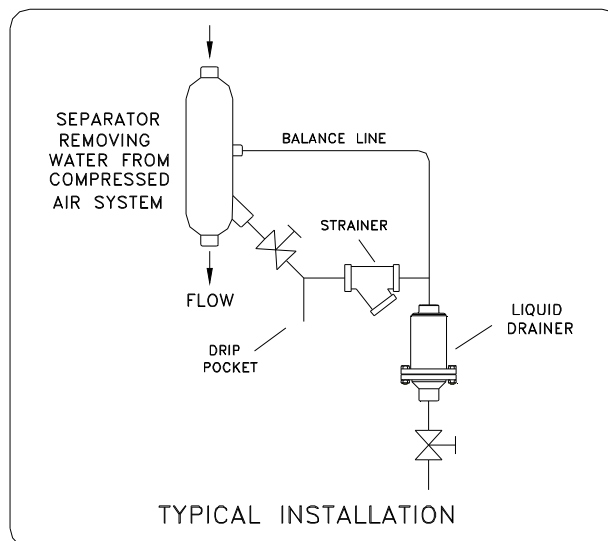
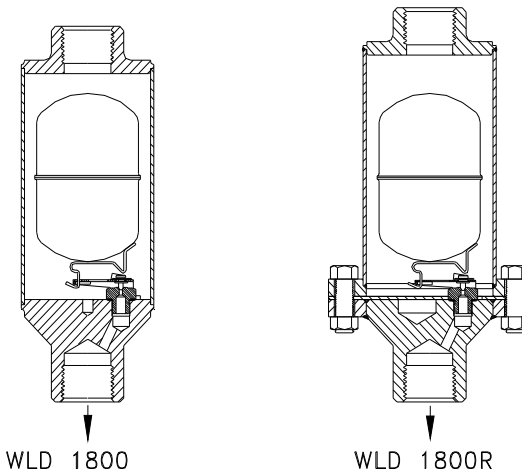

PMO 400 PSIG
PMA 400 PSIG @ 500°F
TMA 500°F @ 400 PSIG

WLD 1800R ASSEMBLY

