

FRM-NOC

Medium Pressure Regulator



Medium Pressure Regulator FRM-NOC

Direct acting pressure regulator without inlet pressure balancing with adjustable setpoint spring and modularly attachable safety shut-off valve (SAV).

In compliance with EN 334 and EN 14382

- Input pressures up to 10 bar (1 000 kPa)
- Rapid response to changes in flows
- 4 to 6 different seat diameters available for each size
- Regulating cup without inlet pressure balancing
- Internal pulse (optional: external pulse)
- Easy maintenance
- Flange connection DN 25 - DN 50 / threaded connection 1"-2"
- For applications with constant input pressure P_u

Table of contents FRM-NOC



Applications	3
Approval	3
Technical data	4+5
Pressure taps	6
Nomenclature	7
Adjustment ranges	8-11
Regulator spring selection	12+15
SAV spring selection	16+17
Dimensions	18-21
Function	22-24
Sectional drawing FRM-NOC/SAV	22-24
Device selection/flow tables	25-27
Contact	28

FRM-NOC

Direct acting (spring-loaded) pressure regulator without inlet pressure balancing with adjustable setpoint spring for controlling the regulator output pressure. Regulator output pressure internal tap (optional: external tap).

Applications

For systems that require rapid response to changes in flows (industrial gas burners and gas burning appliances).

Suitable for gases of gas families 1, 2, 3 and other neutral gaseous media.

Approval

EC type-examination certificate according to:

- EC Pressure Equipment Directive

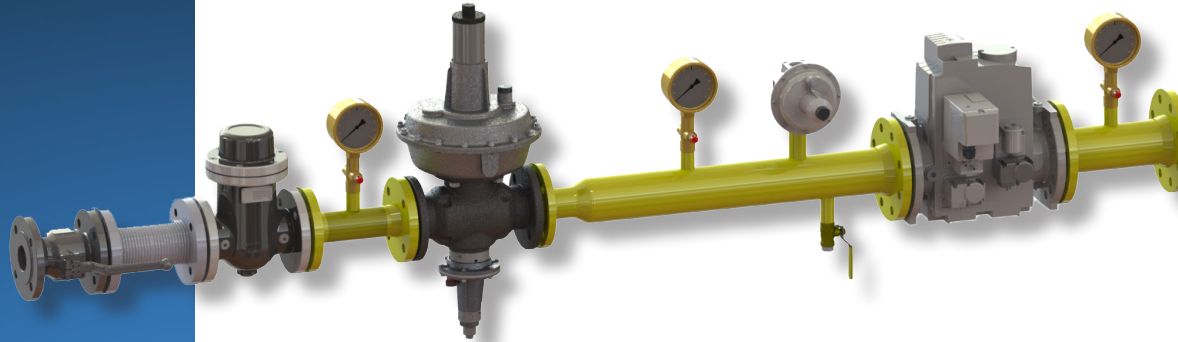

Technical Data FRM-NOC

Medium pressure regulator according to EN 334



Model	DS (differential strength range)
Type of gas	Family 1+2+3 (e.g. manufactured gas (town gas), commercial grade natural gas and commercial grade LPG gases in the vaporized phase).
Nominal diameters of flanges	Connecting flanges PN 25 according to EN 1092-1 or ANSI Class 150 per B16.5 DN 25 40 50 NPS 1" 1.5" 2"
Nominal diameters of threads	Connecting thread in accordance (ISO7/1) or NPT (B1.20.1) Rp 1" 1.5" 2" NPT 1" 1.5" 2"
Max. input pressure	10 bar (1 000 kPa / 145 PSI)
Output pressure range	20 - 4 000 mbar (2 - 400 kPa) / 8 - 1 600 "W.C. (0.3 - 58 PSI)
Minimum inlet pressure (ND)	40 mbar (4 kPa) / 16 "W.C. (0.6 PSI)
Minimum inlet pressure (MD)	160 mbar (16 kPa) / 64 "W.C. (2.3 PSI)
Minimum inlet pressure (HD)	550 mbar (55 kPa) / 220 "W.C. (8 PSI)
Minimum inlet pressure (UHD)	1 250 mbar (125 kPa) / 502 "W.C. (18 PSI)
Control quality	up to AC 5 (see Adjustment ranges on page 8-11)
Closing pressure group	up to SG 10 (see Adjustment ranges on page 8-11)
Failure mode (diaphragm rupture)	Fail-open

Materials	Regulator housing:	Cast iron GJS 400-15
	Diaphragm housing:	Aluminium/steel plate (UHD)
	Diaphragms:	NBR

Ambient temperature -20 °C to + 60 °C / -4 °F to + 140 °F

Technical Data SAV

Safety shut-off valve according to EN 14382

Model	DS (differential strength range)	
Response time	< 2 s	
Lower adjustment range W_{du}	10 mbar to 3 000 mbar (1-300 kPa) / 4 - 1 205 "W.C. (0.3 - 43.5 PSI)	
Upper adjustment range W_{do}	60 mbar to 5 000 mbar (6-500 kPa)/ 24 - 2 007 "W.C. (0.9 - 72.5 PSI)	
Materials	Main body housing:	Cast iron GJS 400-15
	Diaphragm housing:	Aluminium
	Diaphragms:	NBR

Pressure taps

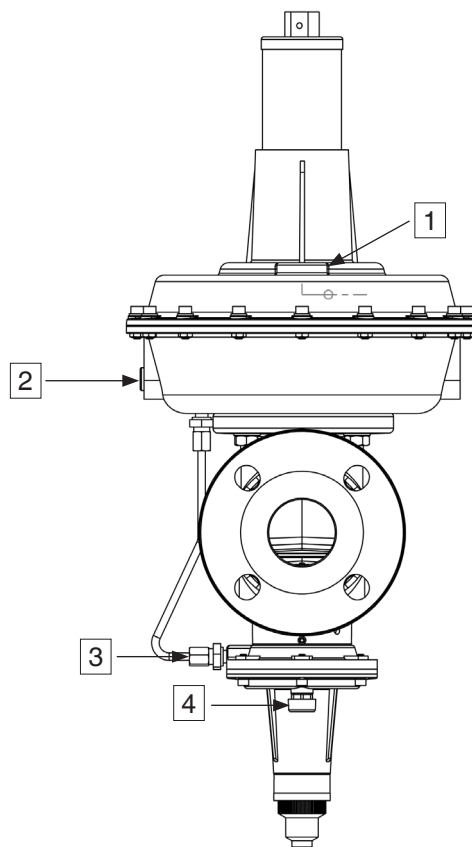

- 1 Regulator vent line connection,
G $\frac{1}{4}$ ISO 228
G $\frac{1}{2}$ ISO 228 (2", DN 40, DN 50 ND, MD)
- 2 Connection for external pulse (optional)
regulator, Ermeto screw connection
GE 12 - $\frac{1}{4}$ for tubes 12x1.5
- 3 Connection for external pulse SAV,
Ermeto screw connection
GE 12 - $\frac{1}{4}$ for tubes 12x1.5
- 4 Vent line connection SAV,
G $\frac{1}{4}$ ISO 228



Example FRM-NOC 100025 ND / SAV ND		100	025	ND	SAV	ND
Type	Spring-loaded medium pressure regulator					
Maximum operating pressure MOP	100 ... 10 000 mbar (1 000 kPa) 4 018 "W.C. (145 PSI)					
Nominal diameter	10 1" 15 1½" 20 2" 025 DN 25 040 DN 40 050 DN 50					
Outlet pressure ranges	ND Low pressure MD Medium pressure HD High pressure UHD Ultra high pressure					
Safety device	SAV Integrated safety cut-off valve					
Pressure range, trip pressure	ND Low pressure MD Medium pressure HD High pressure UHD Ultra high pressure					
Type of thread/flange	with Standard Rp or PN-25 ANSI with flanges ANSI Class 150 NPT with threads NPT					

Adjustment ranges



Type	Conne- ction	Ver- sion	Accu- racy class* [AC]	Closing pressure class* [SG]	Outlet pressure range W_d	Monitoring de- pression SAV	Monitoring over- pressure SAV
						W_{du}	W_{do}
FRM-NOC 10010 ND	Rp 1	ND	10 %	20 %	20-100 mbar 8-40 "W.C.	-	-
FRM-NOC 10010 MD	Rp 1	MD	10 %	20 %	80-400 mbar 32-161 "W.C.	-	-
FRM-NOC 10010 HD	Rp 1	HD	5 %	10 %	300-1 500 mbar 120-602 "W.C.	-	-
FRM-NOC 10010 UHD	Rp 1	UHD	5 %	10 %	1 000-4 000 mbar 400-1 600 "W.C.	-	-
FRM-NOC 10010 ND / SAV ND	Rp 1	ND	10 %	20 %	20-100 mbar 8-40 "W.C.	10-90 mbar 4-36 "W.C.	60-450 mbar 24-180 "W.C.
FRM-NOC 10010 MD / SAV MD	Rp 1	MD	10 %	20 %	80-400 mbar 32-161 "W.C.	10-500 mbar 4-200 "W.C.	60-999 mbar 24-401 "W.C.
FRM-NOC 10010 HD / SAV HD	Rp 1	HD	5 %	10 %	300-1 500 mbar 120-602 "W.C.	150-3 000 mbar 60-1200 "W.C.	600-5 000 mbar 241-2 005 "W.C.
FRM-NOC 10010 UHD / SAV UHD	Rp 1	UHD	5%	10 %	1 000-4 000 mbar 400-1 600 "W.C.	150-3000 mbar 60-1 200 "W.C.	600-5 000 mbar 241-2 005 "W.C.
FRM-NOC 10015 ND	Rp 1½	ND	10 %	20 %	20-100 mbar 8-40 "W.C.	-	-
FRM-NOC 10015 MD	Rp 1½	MD	10 %	20 %	80-400 mbar 32-161 "W.C.	-	-
FRM-NOC 10015 HD	Rp 1½	HD	5 %	10 %	300-1 500 mbar 120-602 "W.C.	-	-
FRM-NOC 10015 UHD	Rp 1½	UHD	5 %	10 %	1 000-4 000 mbar 400- 1 600 "W.C.	-	-
FRM-NOC 10015 ND / SAV ND	Rp 1½	ND	10 %	20 %	20-100 mbar 8-40 "W.C.	10-90 mbar 4-36 "W.C.	60-450 mbar 24-180 "W.C.
FRM-NOC 10015 MD / SAV MD	Rp 1½	MD	10 %	20 %	80-400 mbar 32-161 "W.C.	10-500 mbar 4-200 "W.C.	60-999 mbar 24-401 "W.C.

Adjustment ranges



Type	Con- nection	Ver- sion	Accu- racy class* [AC]	Closing pressure class* [SG]	Outlet pressure range W_d	Monitoring de- pression SAV	Monitoring over- pressure SAV
						W_{du}	W_{do}
FRM-NOC 10015 HD / SAV HD	Rp 1½	HD	5 %	10 %	300-1 500 mbar 120-602 "W.C.	150-3 000 mbar 60-1200 "W.C.	600-5 000 mbar 241-2 005 "W.C.
FRM-NOC 10015 UHD / SAV UHD	Rp 1½	UHD	5 %	10 %	1 000-4 000 mbar 400-1 600 "W.C.	150-3 000 mbar 60-1 200 "W.C.	600-5 000 mbar 241-2 005 "W.C.
FRM-NOC 10020 ND	Rp 2	ND	10 %	20 %	20-100 mbar 8-40 "W.C.	-	-
FRM-NOC 10020 MD	Rp 2	MD	10 %	20 %	80-400 mbar 32-161 "W.C.	-	-
FRM-NOC 10020 HD	Rp 2	HD	5 %	10 %	300-1 500 mbar 120-602 "W.C.	-	-
FRM-NOC 10020 UHD	Rp 2	UHD	5 %	10 %	1 000-4 000 mbar 400-1 600 "W.C.	-	-
FRM-NOC 10020 ND / SAV ND	Rp 2	ND	10 %	20 %	20-100 mbar 8-40 "W.C.	10-90 mbar 4-36 "W.C.	60-450 mbar 24-180 "W.C.
FRM-NOC 10020 MD / SAV MD	Rp 2	MD	10 %	20 %	80-400 mbar 32-161 "W.C.	10-500 mbar 4-200 "W.C.	60-999 mbar 24-401 "W.C.
FRM-NOC 10020 HD / SAV HD	Rp 2	HD	5 %	10 %	300-1 500 mbar 120-602 "W.C.	150-3 000 mbar 60-1200 "W.C.	600-5 000 mbar 241-2 005 "W.C.
FRM-NOC 10020 UHD / SAV UHD	Rp 2	UHD	5 %	10 %	1 000-4 000 mbar 400-1 600 "W.C.	150-3 000 mbar 60-1 200 "W.C.	600-5 000 mbar 241-2 005 "W.C.
FRM-NOC 100025 ND	DN 25	ND	10 %	20 %	20-100 mbar 8-40 "W.C.	-	-
FRM-NOC 100025 MD	DN 25	MD	10 %	20 %	80-400 mbar 32-161 "W.C.	-	-
FRM-NOC 100025 HD	DN 25	HD	5 %	10 %	300-1 500 mbar 120-602 "W.C.	-	-

Adjustment ranges



Type	Conne- ction	Ver- sion	Accu- racy class* [AC]	Closing pressure class* [SG]	Outlet pressure range W_d	Monitoring de- pression SAV	Monitoring over- pressure SAV
						W_{du}	W_{do}
FRM-NOC 100025 UHD	DN 25	UHD	5 %	10 %	1 000-4 000 mbar 400-1 600 "W.C.	-	-
FRM-NOC 100025 ND / SAV ND	DN 25	ND	10 %	20 %	20-100 mbar 8-40 "W.C.	10-90 mbar 4-36 "W.C.	60-450 mbar 24-180 "W.C.
FRM-NOC 100025 MD / SAV MD	DN 25	MD	10 %	20 %	80-400 mbar 32-161 "W.C.	10-500 mbar 4-200 "W.C.	60-999 mbar 24-401 "W.C.
FRM-NOC 100025 HD / SAV HD	DN 25	HD	5 %	10 %	300-1 500 mbar 120-602 "W.C.	150-3 000 mbar 60-1200 "W.C.	600-5 000 mbar 241-2 005 "W.C.
FRM-NOC 100025 UHD / SAV UHD	DN 25	UHD	5 %	10 %	1 000-4 000 mbar 400-1 600 "W.C.	150-3 000 mbar 60-1 200 "W.C.	600-5 000 mbar 241-2 005 "W.C.
FRM-NOC 100040 ND	DN 40	ND	10 %	20 %	20-100 mbar 8-40 "W.C.	-	-
FRM-NOC 100040 MD	DN 40	MD	10 %	20 %	80-400 mbar 32-161 "W.C.	-	-
FRM-NOC 100040 HD	DN 40	HD	5 %	10 %	300-1 500 mbar 120-602 "W.C.	-	-
FRM-NOC 100040 UHD	DN 40	UHD	5 %	10 %	1 000-4 000 mbar 400-1 600 "W.C.	-	-
FRM-NOC 100040 ND / SAV ND	DN 40	ND	10 %	20 %	20-100 mbar 8-40 "W.C.	10-90 mbar 4-36 "W.C.	60-450 mbar 24-180 "W.C.
FRM-NOC 100040 MD / SAV MD	DN 40	MD	10 %	20 %	80-400 mbar 32-161 "W.C.	10-500 mbar 4-200 "W.C.	60-999 mbar 24-401 "W.C.
FRM-NOC 100040 HD / SAV HD	DN 40	HD	5 %	10 %	300-1 500 mbar 120-602 "W.C.	150-3 000 mbar 60-1200 "W.C.	600-5 000 mbar 241-2 005 "W.C.
FRM-NOC 100040 UHD / SAV UHD	DN 40	UHD	5 %	10 %	1 000-4 000 mbar 400-1 600 "W.C.	150-3 000 mbar 60-1 200 "W.C.	600-5 000 mbar 241-2 005 "W.C.

Adjustment ranges



Type	Connec- tion	Ver- sion	Accu- racy class* [AC]	Closing pressure class* [SG]	Outlet pressure range W_d	Monitoring de- pression SAV	Monitoring over- pressure SAV
						W_{du}	W_{do}
FRM-NOC 100050 ND	DN 50	ND	10 %	20 %	20-100 mbar 8-40 "W.C.	-	-
FRM-NOC 100050 MD	DN 50	MD	10 %	20 %	80-400 mbar 32-161 "W.C.	-	-
FRM-NOC 100050 HD	DN 50	HD	5 %	10 %	300-1 500 mbar 120-602 "W.C.	-	-
FRM-NOC 100050 UHD	DN 50	UHD	5 %	10 %	1 000-4 000 mbar 400-1 600 "W.C.	-	-
FRM-NOC 100050 ND / SAV ND	DN 50	ND	10 %	20 %	20-100 mbar 8-40 "W.C.	10-90 mbar 4-36 "W.C.	60-450 mbar 24-180 "W.C.
FRM-NOC 100050 MD / SAV MD	DN 50	MD	10 %	20 %	80-400 mbar 32-161 "W.C.	10-500 mbar 4-200 "W.C.	60-999 mbar 24-401 "W.C.
FRM-NOC 100050 HD / SAV HD	DN 50	HD	5 %	10 %	300-1 500 mbar 120-602 "W.C.	150-3 000 mbar 60-1200 "W.C.	600-5 000 mbar 241-2 005 "W.C.
FRM-NOC 100050 UHD / SAV UHD	DN 50	UHD	5 %	10 %	1 000-4 000 mbar 400-1 600 "W.C.	150-3 000 mbar 60-1 200 "W.C.	600-5 000 mbar 241-2 005 "W.C.

Regulator spring selection

The output pressure results from the force of the adjusting spring installed and the weight of the moving parts. By changing **adjusting spring 1** it is possible to achieve different output pressures.

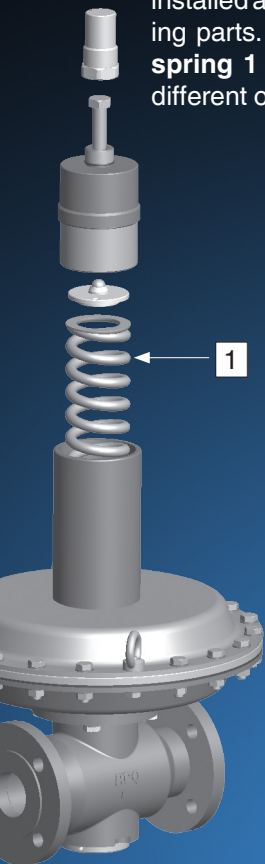

Outlet pressure adjustment range W _{ds} FRM-NOC 10010 / 10015 / 100025								
Spring colour	Item N°	Wire Ø [mm]	Ø [mm]	Length [mm]	Adjustment range			
					ND	MD	HD	UHD
Red	287881	2.5	37	134	20-35 mbar 8-14 "W.C.			
White	287882	2.8	37	134	30-50 mbar 12-20 "W.C.			
Yellow	287883	3	37	134	50-75 mbar 20-30 "W.C.			
Blue	274969	3.2	37	130	60-100 mbar 24-40 "W.C.	80-150 mbar 32-60 "W.C.		
Black	274970	3.5	37	130		100-200 mbar 40-80 "W.C.		
Purple	274971	3.7	37	130		130-250 mbar 52-100 "W.C.		
Orange	274972	4	37	130		180-350 mbar 72-141 "W.C.		
Pink	274973	4.3	37	130		200-400 mbar 80-161 "W.C.		
White 2	287888	4.5	35	100			300-500 mbar 120-201 "W.C.	
Yellow 2	287889	5	35	100			450-700 mbar 181-281 "W.C.	
Blue 2	287890	5.5	35	100			550-900 mbar 221-361 "W.C.	

Outlet pressure adjustment range W_{ds} FRM-NOC 10010 / 10015 / 100025								
Spring colour	Item N°	Wire Ø [mm]	Ø [mm]	Length [mm]	Adjustment range			
					ND	MD	HD	UHD
Black 2	287891	6	35	100			650-1 150 mbar 261-462 "W.C.	
Purple 2	287892	6.5	35	100			1 000-1 500 mbar 401-602 "W.C.	
Purple 3	287893	10	70	155				1 000-1 600 mbar 401-642 "W.C.
Orange 2	287894	11	70	155				1 500-2 400 mbar 602-964 "W.C.
Pink 2	287895	12	73	155				2 300-3 600 mbar 923-1 445 "W.C.
Red 2	287896	13	74	160				3 500-4 000 mbar 1 405-1 606 "W.C.

Regulator spring selection

The output pressure results from the force of the adjusting spring installed and the weight of the moving parts. By changing **adjusting spring 1** it is possible to achieve different output pressures.

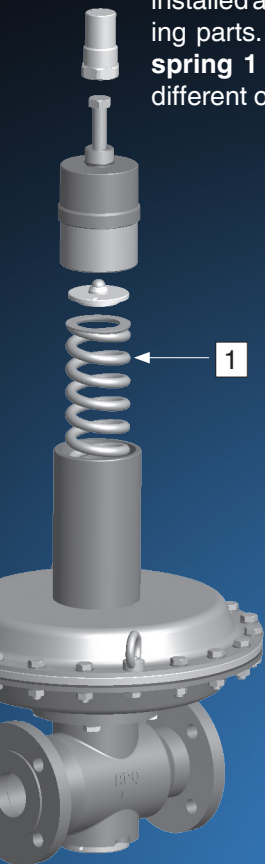

Outlet pressure adjustment range W _{ds} FRM-NOC 10020 / 100040 / 100050								
Spring colour	Item N°	Wire Ø [mm]	Ø [mm]	Length [mm]	Adjustment range			
					ND	MD	HD	UHD
Yellow	287884	3.5	50	220	20-25 mbar 8-10 "W.C.			
Blue	287885	4	50	220	25-45 mbar 10-18 "W.C.			
Black	287886	4.5	50	220	30-65 mbar 12-26 "W.C.			
Silver	287887	5	50	220	50-100 mbar 20-40 "W.C.			
Pink	274982	5.5	50	260		80-150 mbar 32-60 "W.C.		
Green	274983	6	50	260		130-250 mbar 52-100 "W.C.		
Blue 2	274985	7	50	240		200-350 mbar 80-141 "W.C.		
Black 2	274986	8	50	240		300-400 mbar 120-161 "W.C.		
White	287888	4.5	35	100			300-500 mbar 120-201 "W.C.	
Yellow 2	287889	5	35	100			450-700 mbar 181-281 "W.C.	
Blue 3	287890	5.5	35	100			550-900 mbar 221-361 "W.C.	

Outlet pressure adjustment range W_{ds} FRM-NOC 10020 / 100040 / 100050								
Spring colour	Item N°	Wire Ø [mm]	Ø [mm]	Length [mm]	Adjustment range			
					ND	MD	HD	UHD
Black 2	287891	6	35	100			650-1 150 mbar 261-462 "W.C.	
Purple 2	287892	6.5	35	100			1 000-1 500 mbar 401-602 "W.C.	
Purple 3	287893	10	70	155				1 000-1 600 mbar 401-642 "W.C.
Orange 2	287894	11	70	155				1 500-2 400 mbar 602-964 "W.C.
Pink 2	287895	12	73	155				2 300-3 600 mbar 923-1 445 "W.C.
Red 2	287896	13	74	160				3 500-4 000 mbar 1 405-1 606 "W.C.

SAV springs selection

The output pressure results from the force of the adjusting spring installed. The upper response pressure (W_{dso} overpressure) is set on external **spring 1** of the measurement device. The lower response pressure (W_{dsu} underpressure) can be set on internal **spring 2**. By changing the adjusting springs the response pressures are changed.

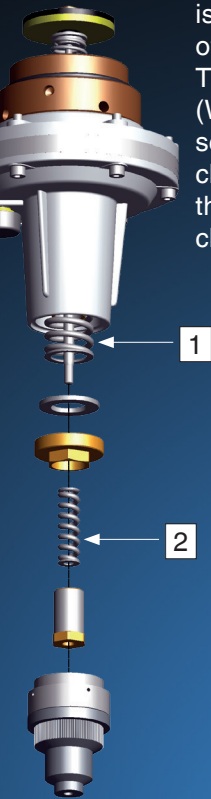

Specific adjustment range, underpressure W_{dsu}						
Spring colour	Order number	Wire diameter [mm]	Length [mm]	Diameter [mm]	Setpoint range [mbar]	
					ND-MD	HD-UHD
Yellow	303335	1,4	58,5	13	10 - 30	-
Blue	303336	1,6	58,2	13	25 - 90	150 - 290
Black	303337	1,8	58,3	13	70 - 160	250 - 560
Purple	303338	2	58,3	13	140 - 310	520 - 1100
Orange	303339	2,25	58,3	13	290 - 500	1 050 - 1 800
Pink	303340	2,5	58,2	13	-	1 650 - 3 000

Specific adjustment range, overpressure W_{dso}						
Spring colour	Order number	Wire diameter [mm]	Length [mm]	Diameter [mm]	Setpoint range [mbar]	
					ND-MD	HD-UHD
Silver	303321	2,4	55,2	30	60 - 140	-
Green	303322	2,8	55	30	80 - 220	-
Red	303323	3,2	54,6	30	160 - 450	600 - 1 700
Yellow	303324	3,6	54,5	30	300 - 680	1 250 - 2 500
Blue	303325	4	54,5	30	500 - 999	1 900 - 4 500
Black	303326	4,25	54,4	30	-	3 500 - 5 000

Dimensions FRM-NOC

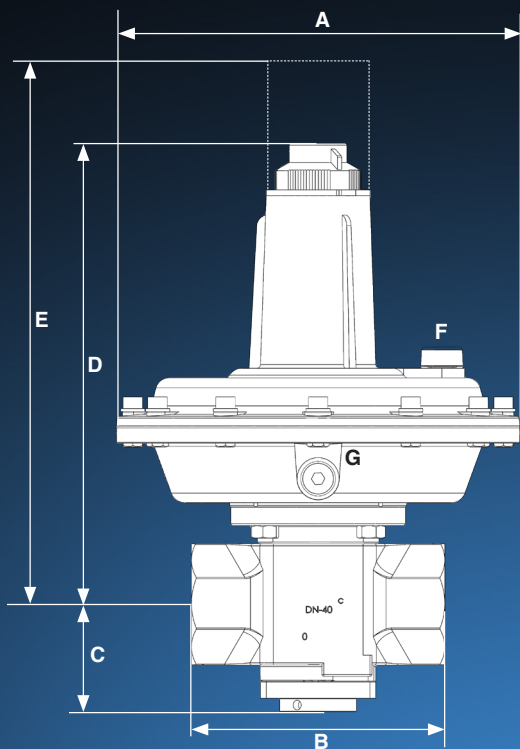

Type	Item N°		p _{max.} [bar/kPa/PSI]	DN	Dimensions [mm]							Weight [kg/lbs]
	Rp	NPT			A	B	C	D	E	F	G*	
FRM-NOC 10010 ND	279054	280236	10 / 1 000 / 145	1"	210	104	57	240	250	¼"G	¼"G	5/11.0
FRM-NOC 10010 MD	279055	280237	10 / 1 000 / 145	1"	210	104	57	240	250	¼"G	¼"G	5/11.0
FRM-NOC 10010 HD	279058	280238	10 / 1 000 / 145	1"	210	104	57	240	250	¼"G	¼"G	5/11.0
FRM-NOC 10010 UHD	279059	280239	10 / 1 000 / 145	1"	210	104	57	342	667	¼"G	¼"G	9/19.8
FRM-NOC 10015 ND	279060	280240	10 / 1 000 / 145	1½"	210	132	57	240	250	¼"G	¼"G	6/13.2
FRM-NOC 10015 MD	279061	280241	10 / 1 000 / 145	1½"	210	132	57	240	250	¼"G	¼"G	6/13.2
FRM-NOC 10015 HD	279062	280242	10 / 1 000 / 145	1½"	210	132	57	240	250	¼"G	¼"G	6/13.2
FRM-NOC 10015 UHD	279063	280243	10 / 1 000 / 145	1½"	210	132	57	342	667	¼"G	¼"G	10/22.0
FRM-NOC 10020 ND	279064	280244	10 / 1 000 / 145	2"	280	156	61	345	495	½"G	¼"G	12/26.5
FRM-NOC 10020 MD	279065	280245	10 / 1 000 / 145	2"	280	156	61	345	495	½"G	¼"G	12/26.5
FRM-NOC 10020 HD	279066	280246	10 / 1 000 / 145	2"	210	156	61	245	255	¼"G	¼"G	11/24.3
FRM-NOC 10020 UHD	279067	280247	10 / 1 000 / 145	2"	210	156	61	345	670	¼"G	¼"G	16/35.2

*G for external tap (optional)

Dimensions FRM-NOC

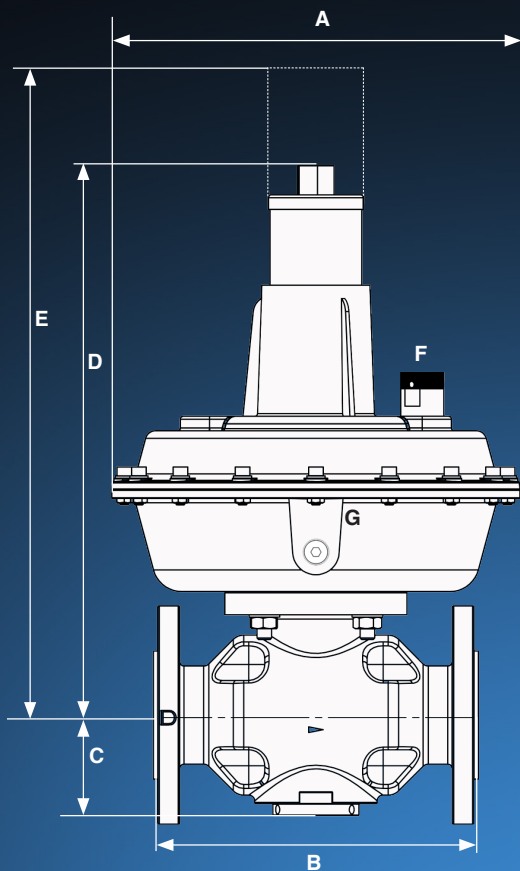

Type	Item N°		p _{max.} [bar/kPa/PSI]	DN	Dimensions [mm]							Weight [kg/lbs]
	DN	NPS			A	B	C	D	E	F	G*	
FRM-NOC 100025 ND	279085	280260	10 / 1 000 / 145	25	210	184	50	260	270	¼ "G	¼ "G	9/19.8
FRM-NOC 100025 MD	279086	280261	10 / 1 000 / 145	25	210	184	50	260	270	¼ "G	¼ "G	9/19.8
FRM-NOC 100025 HD	279087	280262	10 / 1 000 / 145	25	210	184	50	260	270	¼ "G	¼ "G	9/19.8
FRM-NOC 100025 UHD	279088	280263	10 / 1 000 / 145	25	210	184	50	362	687	¼ "G	¼ "G	13/28.7
FRM-NOC 100040 ND	279089	280264	10 / 1 000 / 145	40	280	223	70	350	500	½ "G	¼ "G	17/37.5
FRM-NOC 100040 MD	279090	280265	10 / 1 000 / 145	40	280	223	70	350	500	½ "G	¼ "G	17/37.5
FRM-NOC 100040 HD	279091	280266	10 / 1 000 / 145	40	210	223	70	250	260	¼ "G	¼ "G	16/35.2
FRM-NOC 100040 UHD	279092	280267	10 / 1 000 / 145	40	210	223	70	350	675	¼ "G	¼ "G	21/46.3
FRM-NOC 100050 ND	279093	280268	10 / 1 000 / 145	50	280	254	80	400	550	½ "G	¼ "G	20/44.1
FRM-NOC 100050 MD	279094	280269	10 / 1 000 / 145	50	280	254	80	400	550	½ "G	¼ "G	20/44.1
FRM-NOC 100050 HD	279095	280270	10 / 1 000 / 145	50	210	254	80	300	310	¼ "G	¼ "G	19/41.9
FRM-NOC 100050 UHD	279096	280271	10 / 1 000 / 145	50	210	254	80	395	720	¼ "G	¼ "G	24/52.9

*G for external tap (optional)

Dimensions FRM-NOC with SAV

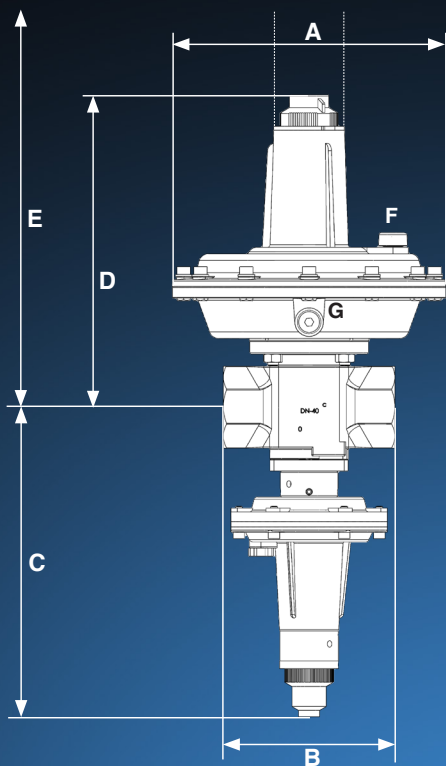

Type	Item N°		p _{max.} [bar/kPa]	DN	Dimensions [mm]							Weight [kg/lbs]
	Rp	NPT			A	B	C	D	E	F	G*	
FRM-NOC 10010 ND /SAV ND	279042	280224	10 / 1000 / 145	1"	210	104	267	240	250	¼"G	¼" G	7/15.4
FRM-NOC 10010 MD /SAV MD	279043	280225	10 / 1000 / 145	1"	210	104	267	240	250	¼"G	¼" G	7/15.4
FRM-NOC 10010 HD /SAV HD	279044	280226	10 / 1000 / 145	1"	210	104	267	240	250	¼"G	¼" G	7/15.4
FRM-NOC 10010 UHD /SAV UHD	279045	280227	10 / 1000 / 145	1"	210	104	267	342	667	¼"G	¼" G	11/24.3
FRM-NOC 10015 ND /SAV ND	279046	280228	10 / 1000 / 145	1½"	210	132	263	240	250	¼"G	¼" G	8/17.6
FRM-NOC 10015 MD /SAV MD	279047	280229	10 / 1000 / 145	1½"	210	132	263	240	250	¼"G	¼" G	8/17.6
FRM-NOC 10015 HD /SAV HD	279048	280230	10 / 1000 / 145	1½"	210	132	263	240	250	¼"G	¼" G	8/17.6
FRM-NOC 10015 UHD /SAV UHD	279049	280231	10 / 1000 / 145	1½"	210	132	263	342	667	¼"G	¼" G	12/26.5
FRM-NOC 10020 ND /SAV ND	279050	280232	10 / 1000 / 145	2"	280	156	268	345	495	½"G	¼" G	14/30.9
FRM-NOC 10020 MD /SAV MD	279051	280233	10 / 1000 / 145	2"	280	156	268	345	495	½"G	¼" G	14/30.9
FRM-NOC 10020 HD /SAV HD	279052	280234	10 / 1000 / 145	2"	210	156	268	245	255	¼"G	¼" G	13/28.7
FRM-NOC 10020 UHD /SAV UHD	279053	280235	10 / 1000 / 145	2"	210	156	268	345	670	¼"G	¼" G	18/39.7

*G for external tap (optional)

Dimensions FRM-NOC with SAV

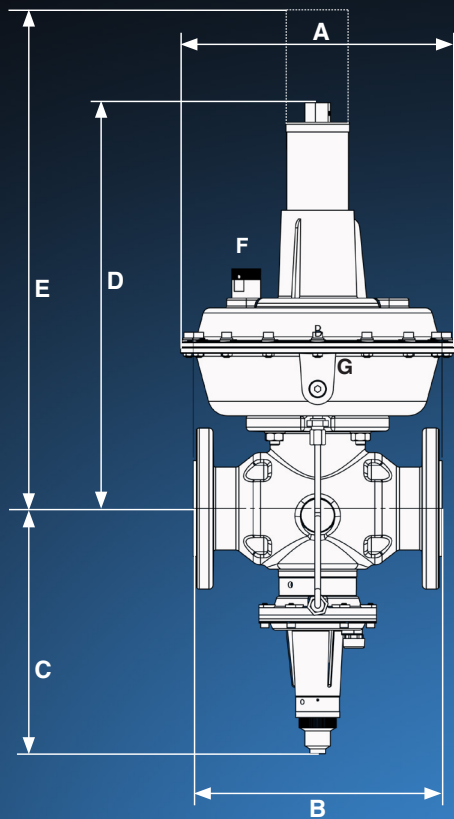

Type	Item N°		P _{max.} [bar/kPa]	DN	Dimensions [mm]							Weight [kg/lbs]
	DN	NPS			A	B	C	D	E	F	G*	
FRM-NOC 100025 ND /SAV ND	279073	280248	10 / 1000 / 145	25	210	184	267	260	270	¼ "G	¼ "G	11/24.3
FRM-NOC 100025 MD /SAV MD	279074	280249	10 / 1000 / 145	25	210	184	267	260	270	¼ "G	¼ "G	11/24.3
FRM-NOC 100025 HD /SAV HD	279075	280250	10 / 1000 / 145	25	210	184	267	260	270	¼ "G	¼ "G	11/24.3
FRM-NOC 100025 UHD /SAV UHD	279076	280251	10 / 1000 / 145	25	210	184	267	362	687	¼ "G	¼ "G	15/33.1
FRM-NOC 100040 ND /SAV ND	279077	280252	10 / 1000 / 145	40	280	223	273	350	500	½ "G	¼ "G	19/41.9
FRM-NOC 100040 MD /SAV MD	279078	280253	10 / 1000 / 145	40	280	223	273	350	500	½ "G	¼ "G	19/41.9
FRM-NOC 100040 HD /SAV HD	279079	280254	10 / 1000 / 145	40	210	223	273	250	260	¼ "G	¼ "G	18/39.7
FRM-NOC 100040 UHD /SAV UHD	279080	280255	10 / 1000 / 145	40	210	223	273	350	675	¼ "G	¼ "G	23/50.7
FRM-NOC 100050 ND /SAV ND	279081	280256	10 / 1000 / 145	50	280	254	276	400	550	½ "G	¼ "G	22/48.5
FRM-NOC 100050 MD /SAV MD	279082	280257	10 / 1000 / 145	50	280	254	276	400	550	½ "G	¼ "G	22/48.5
FRM-NOC 100050 HD /SAV HD	279083	280258	10 / 1000 / 145	50	210	254	276	300	310	¼ "G	¼ "G	21/46.3
FRM-NOC 100050 UHD /SAV UHD	279084	280259	10 / 1000 / 145	50	210	254	276	395	720	¼ "G	¼ "G	26/57.3

*G for external tap (optional)

Function

Operation according to the force comparison principle between the force:

- of the adjustable setpoint spring,
- from the input pressure against the regulating cup,
- from the differential pressure on the working diaphragm and
- the weight of the moving parts.

The adjusting spring functions independently of the weight of the moving parts. The output pressure self-adjusts relative to pre-tension of the adjusting spring.

Information

Gas carrying, pulse lines and connecting lines must be resistant to thermal, chemical and mechanical stresses. They must also be durable and resistant to deformation and cracks.

 **Condensate from pulse lines must not flow into the pressure regulator.**

 **Combustion gas or gas/air mixtures must not enter the installation space of the adjusting spring.**

Sectional drawing FRM-NOC Pressure regulator in the open position

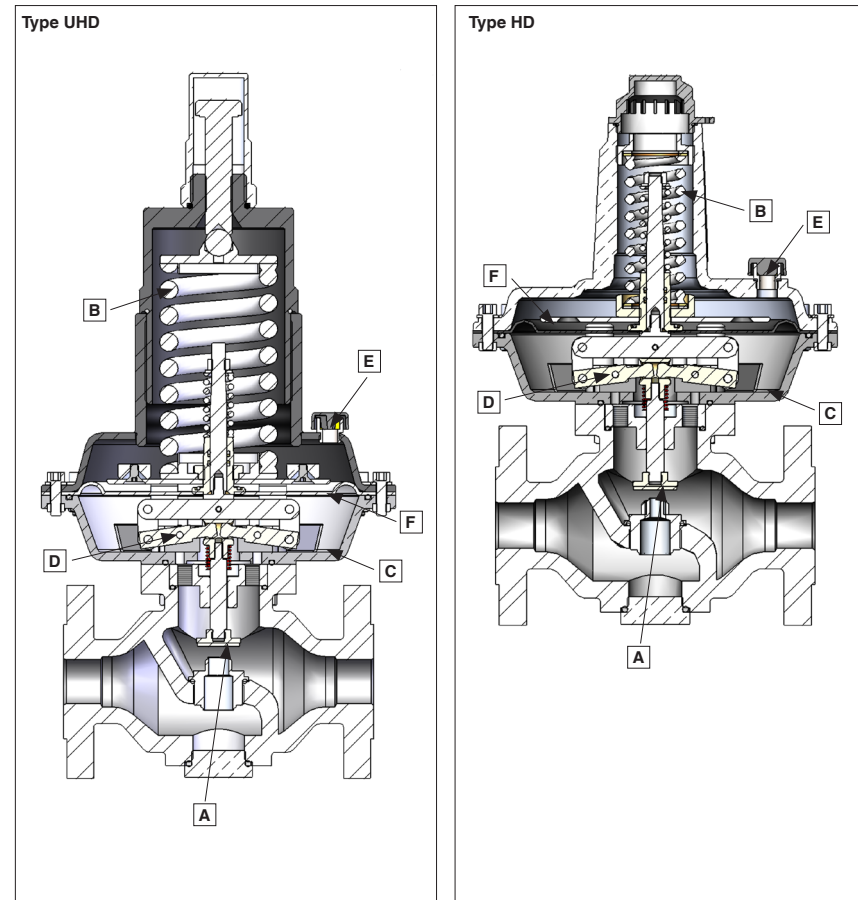

- A** Regulating cup
- B** Setpoint spring
- C** Lower diaphragm case
- D** Lever system
- E** Vent connection
- F** Working diaphragm

When the output pressure increases, the force acting on the working diaphragm **F** in the diaphragm case **C** builds up. As a result, the working diaphragm **F** is moved up until the balance of forces between the force of the setpoint spring **B** and that of the output pressure is established. The upward motion of the working diaphragm **F** pulls the lever system **D** up, by which the regulating cup **A** is pressed down and the valve gap is reduced. The flow thus minimised reduces the output pressure until the nominal value (output pressure) set is reached and the balance of forces is re-established on the working diaphragm **F**.

Function

Operation according to the force comparison principle between the force:

- of the adjustable setpoint spring,
- from the input pressure against the regulating cup,
- from the differential pressure on the working diaphragm and
- the weight of the moving parts.

The adjusting spring functions independently of the weight of the moving parts. The output pressure self-adjusts relative to pre-tension of the adjusting spring.

Information

Gas carrying, pulse lines and connecting lines must be resistant to thermal, chemical and mechanical stresses. They must also be durable and resistant to deformation and cracks.

 **Condensate from pulse lines must not flow into the pressure regulator.**

 **Combustible gas and gas/air mixtures must not enter the installation space of the adjusting spring.**

Sectional drawing FRM-NOC Pressure regulator in the open position

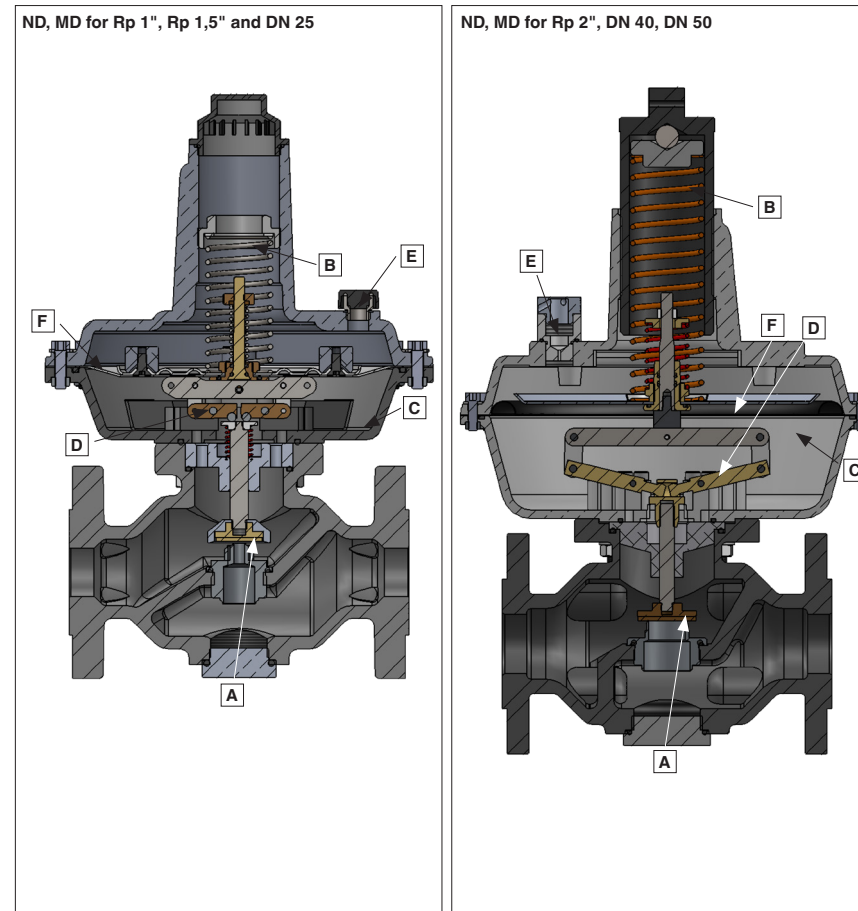

- A** Regulating cup
- B** Setpoint spring
- C** Lower diaphragm case
- D** Lever system
- E** Vent connection
- F** Working diaphragm

When the output pressure increases, the force acting on the working diaphragm **F** in the diaphragm case **C** builds up. As a result, the working diaphragm **F** is moved up until the balance of forces between the force of the setpoint spring **B** and that of the output pressure is established. The upward motion of the working diaphragm **F** pulls the lever system **D** up, by which the regulating cup **A** is pressed down and the valve gap is reduced. The flow thus minimised reduces the output pressure until the nominal value (output pressure) set is reached and the balance of forces is re-established on the working diaphragm **F**.

Function



Sectional drawing SAV
Device in the closed position

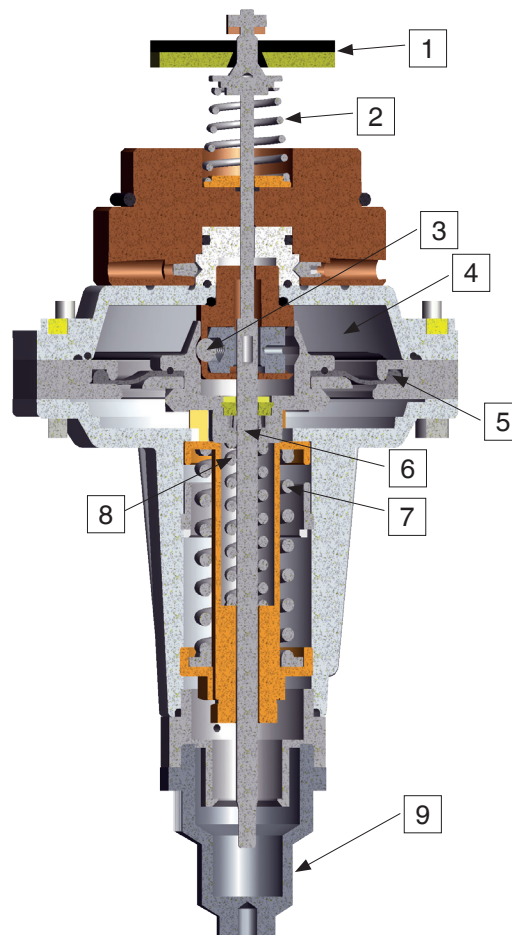



Chamber 4 is connected to the output pressure via a pulse line. The pressure to be controlled acts on working diaphragm 5. The force of setpoint springs 7 and 8 acts as a counterforce. In case of an unbalance of forces (overpressure or underpressure) the SAV is actuated and the gas supply is blocked.

- 1 Valve disc
- 2 Closing spring
- 3 Ball catch / trigger mechanism
- 4 Chamber with the pressure to be monitored
- 5 Working diaphragm
- 6 Push rod
- 7 Setpoint spring for p_{do}
- 8 Setpoint spring for p_{du}
- 9 Protective cap

Device selection

The following flow tables can be used to select the device. The maximum volume flow rate indicated refers to natural gas with a density of 0.81 kg/m^3 at 15 °C under normal conditions. In case of different types of gases, a conversion of the volume flow rate according to the equation on page 26 is carried out. Using the design tables, the maximum flow of the respective regulator can be determined at the operating point defined in terms of p_d and p_u . This involves the maximum power of the regulator, at which accuracy class AC 10 is maintained.

-  **Design a straight stabilisation section with a uniform diameter.**
-  **Pulse tap (optional) at a distance of $> 5 \times \text{DN}$.**
-  **Maximum flow velocity in the stabilisation section $\leq 30 \text{ m/s}$.**

Flow tables AC 10: See document No. 288127 “Flow Tables FRM-NOC”.

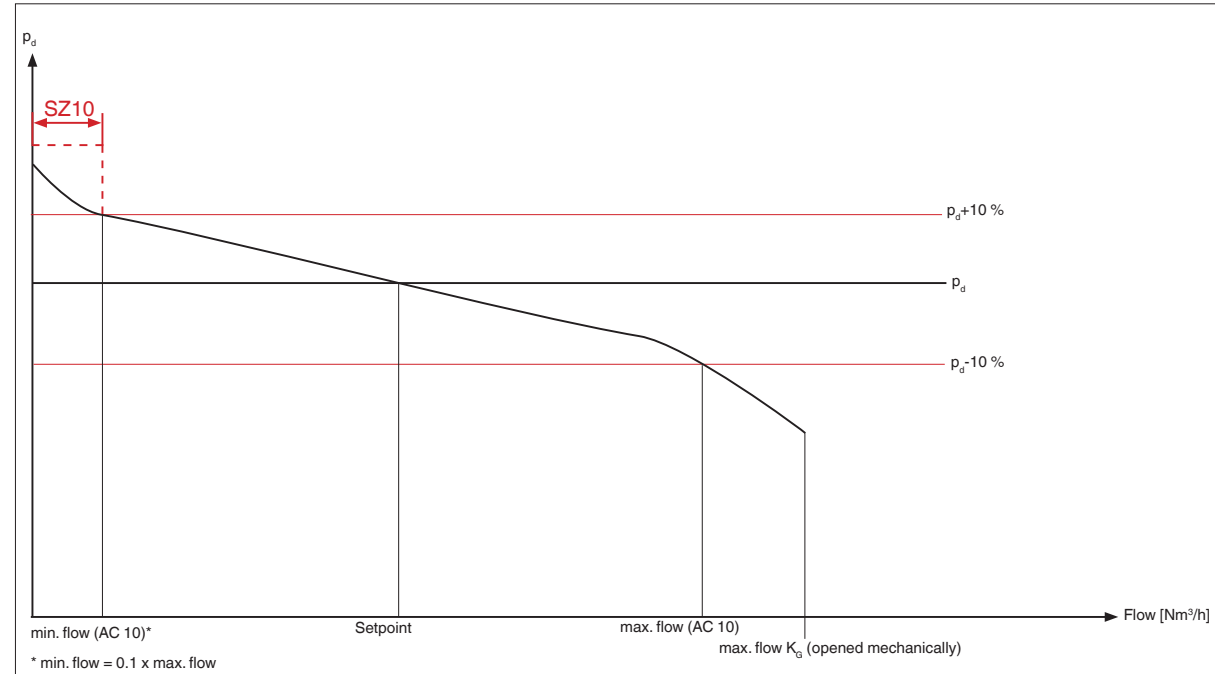

Calculation of gas types



$$\dot{V}_{\text{gas used}} = \dot{V}_{\text{air}} \times f$$

$$f = \sqrt{\frac{\text{air density}}{\text{spec. weight of the gas used}}}$$

Type of gas	Density	dv	f
	[kg/m ³]		
Natural gas	0.81	0.65	1.24
City gas	0.58	0.47	1.46
Liquid gas	2.08	1.67	0.77
Air	1.24	1.00	1.00

Flow coefficients K_G



Type	Valve core thread	Valve core diameter [mm]									
		Ø 6	Ø 8	Ø 10	Ø 12	Ø 14	Ø 16	Ø 20	Ø 25	Ø 30	Ø 35
1", 1½"	M22	34	61	87	115	144					
DN 25	M30	34	61	87	115	144					
2", DN 40	M45			105			279	396	546		
DN 50	M56				151		282	412	575	737	900

Calculation according to maximum power (opened mechanically):

The K_G value required for the application is determined using the following formulas. Then the regulator valve core is selected using a higher K_G value than the one calculated. Only applies in case of an external tap.

a) subcritical or critical pressure ratio

$$\frac{p_{d, \text{abs.}}}{p_{u, \text{abs.}}} \geq 0.53$$

$$K_G = \frac{Q_N}{\sqrt{(p_u + 1.013) \cdot (p_u - p_d)}}$$

Abbreviation	Description
p_d [bar]	Output pressure
$p_{d, \text{abs.}}$ [bar]	Output pressure as absolute pressure ($p_d + 1.013$)
p_u [bar]	Input pressure
$p_{u, \text{abs.}}$ [bar]	Input pressure as absolute pressure ($p_u + 1.013$)

b) supercritical pressure ratio

$$\frac{p_{d, \text{abs.}}}{p_{u, \text{abs.}}} < 0.53$$

$$K_G = \frac{Q_N \cdot \sqrt{2}}{(p_u + 1.013)}$$

with

Q_N = regulator power under normal conditions



FRM-NOC DN 50 UHD



FRM-NOC DN 40 HD



FRM-NOC DN 40 MD



FRM-NOC DN 25 HD

Subject to technical modification in the interest of technical progress.

Karl Dungs GmbH & Co. KG
Karl-Dungs-Platz 1
D-73660 Urbach,
Germany
Phone +49 7181-804-0
Telefax +49 7181-804-166
E-mail: info@dungs.com
Internet: www.dungs.com