

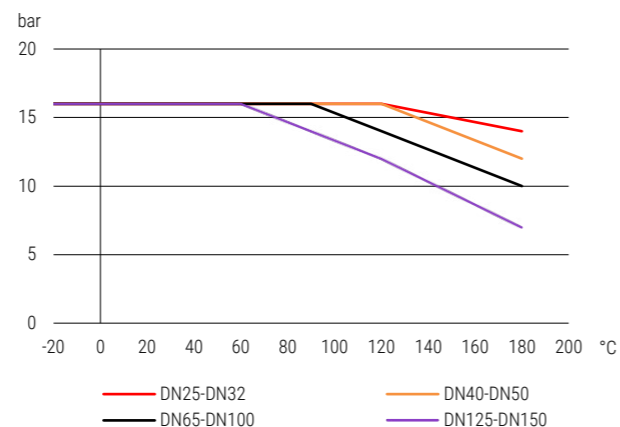

KSL75F | Hebelgriff | FI/FI | Kugel Edelstahl
KSL75F | Lever handle | FI/FI | Ball stainless steel

Druck-Temperatur-Diagramm pressure-temperature-diagram

Konstruktionsmerkmale Kugelhahn

- Schwimmende Kugel
- Ausblässichere Schaltwelle
- Wartungsfrei
- Gekammerte Dichtung
- Montageflansch nach DIN ISO 5211
- Silikonfrei
- Fire Safe Design
- Voller Durchgang
- Zweiteiliges Gehäuse verschraubt
- Optional mit GGVSEB siehe Kapitel Zulassungen und Zeugnisse

Standardtemperaturbereich

- 20°C bis + 180°C (abhängig vom Betriebsdruck)
 Siehe Druck-Temperaturdiagramm

Zulassungstext

Einstufung nach PED Kategorie 2 PED 2014-68-EU, TA-Luft Zulassung nach DIN EN ISO 15848, LABS konform nach VDMA 24364

Verwendung

Öl, Thermoöl, Wasser allgemein, Polyol, Isocyanat, Wasser-Glykol-Mischungen, Heizungskreisläufe, Heizöl, Kraftstoffe, Druckluft, Tyfocor

Design features ball valve

- Floating ball
- Blow out proved stem design
- Maintenance-free
- 3 side guided ball seals
- Mounting pad acc. to DIN ISO 5211
- Free of silicon
- Fire Safe Design
- Full port
- Two-piece body screwed design
- Optional with GGVSEB have a look at chapter approvals and certifications

Standard temperature range

- 20°C to + 180°C (depending on working pressure)
 Take a look at the pressure-temperature-diagram

Approval text

Classification acc.to PED category 2 PED 2014-68-EU, TA-Air approval acc. to DIN EN ISO 15848, LABS conformity acc. to VDMA 24364

Suitable for

Oils, Thermo-oil, general water, Polyol, Isocyanate, Water-glycol mixture, Heating circuits, Heating oil, Fuels, Compressed air, Tyfocor

BESTELBEISPIEL: Flansch-Kugelhahn mit Edelstahlkugel DN65 = KSL75F-DN65 Artikel-Nr. 00V41136
ORDERING EXAMPLE: Flange ball valve with stainless steel ball DN65 = KSL75F-DN65 item number 00V41136

Datentabelle data table

DN	LW	PN	L	MM	R	H	h	D	K	g	z	d	SW1	M	d1	d2	Gewicht Weight	Artikel-Nr. Item number
(mm)	(mm)	(bar)	(mm)	(mm)	(mm)	(mm)	(mm)	(mm)	(mm)	(mm)	(mm)	(mm)	(mm)	(mm)	(mm)	(mm)	(kg)	
25	25	16	125	62,5	165	111,5	60	115	85	68	4	14	11	F05	50	6,6	3,300	00V41016
32	32	16	130	65	165	122,5	71	140	100	78	4	18	11	F05	50	6,6	4,500	00V41046
40	40	16	140	70	185	134	77	150	110	88	4	18	14	F05	50	6,6	5,700	00V41076
50	50	16	150	75	185	142	85	165	125	102	4	18	14	F05	50	6,6	7,600	00V41106
65	65	16	170	85	230	154,5	95	185	145	122	4	18	17	F07	70	9	12,000	00V41136
80	80	16	180	90,5	360	180,5	103,5	200	160	136	8	18	22	F07	70	9	15,500	00V41166
100	100	16	190	92	360	197	120	220	180	158	8	18	22	F10	102	11	22,600	00V41196
125	125	16	200	98	360	216	139	250	210	188	8	18	22	F10	102	11	30,400	00V41248
150	142	16	210	100	556	236	158	285	240	212	8	22	27	F10	102	11	42,000	00V41278

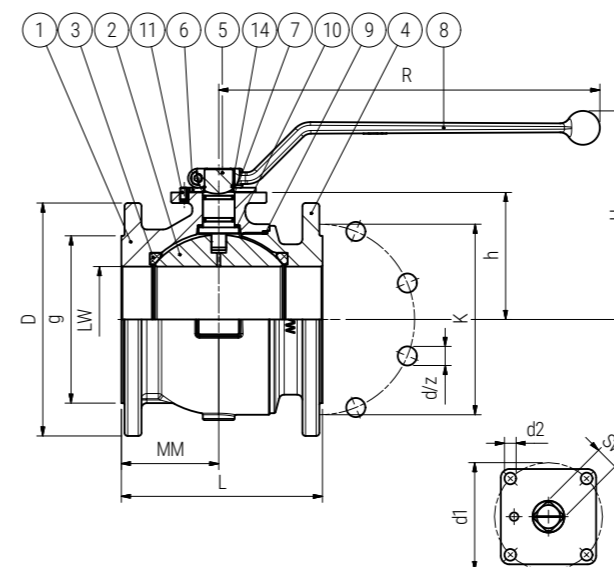
Maßskizze measured sketch

Materialtabelle materials grid

Nr. No.	Bezeichnung Description	Werkstoff Material	Materialbezeichnung Material description
1	Gehäuse Body	Sphäroguss Nodular cast iron	5.3103
2	Kugel Ball	Edelstahl Stainless steel	1.4404
3	Kugeldichtung Ball seal	PTFE GF PTFE GF	-
4	Flansch / Nippel Flange / nipple	Sphäroguss Nodular cast iron	5.3103
5	Schaltwelle Stem	Edelstahl Stainless steel	1.4104
6	Anschlagscheibe Stop plate	Stahl verzinkt Steel (zinc-plated)	-
7	Spindeldichtung Spindle seal	FKM FKM	-
8	Griff Handle	Aluminium Aluminium	-
9	Gehäusedichtung Body seal	FKM FKM	-
10	Anlauftring Thrust washer	Polyamid Polyamide	-
11	Anschlagstift Stop pin	Stahl verzinkt Steel (zinc-plated)	-
14	Federring Clip ring	Federstahl Spring steel	1.4310

Losbrechmomente breakaway torque

DN (mm)	PN0 (Nm)	PN7 (Nm)	PN16 (Nm)
25	7	7	7
32	12	12	12
40	13	13	13
50	19	19	19
65	30	30	30
80	50	50	70
100	60	65	80
125	70	70	100
150	100	100	130